

NOTES:

1. TO INSPECT ASSEMBLY, FOLLOW FIRST ARTICLE AND IN PROCESS INSPECTION SHEET.

BILL OF MATERIAL (CURRENT LEVEL)

| ITEM | PT/ASSY | DESCRIPTION | TYPE | QTY. |
|------|---------|---------------------------------|----------|------|
| 1 | 1995 | MOUNTING FLANGE | PART | 2 |
| 2 | 199X | GRAB BAR MOUNTING HARDWARE PACK | ASSEMBLY | 2 |
| 3 | 40681 | GRAB BAR TRIM RING | PART | 2 |

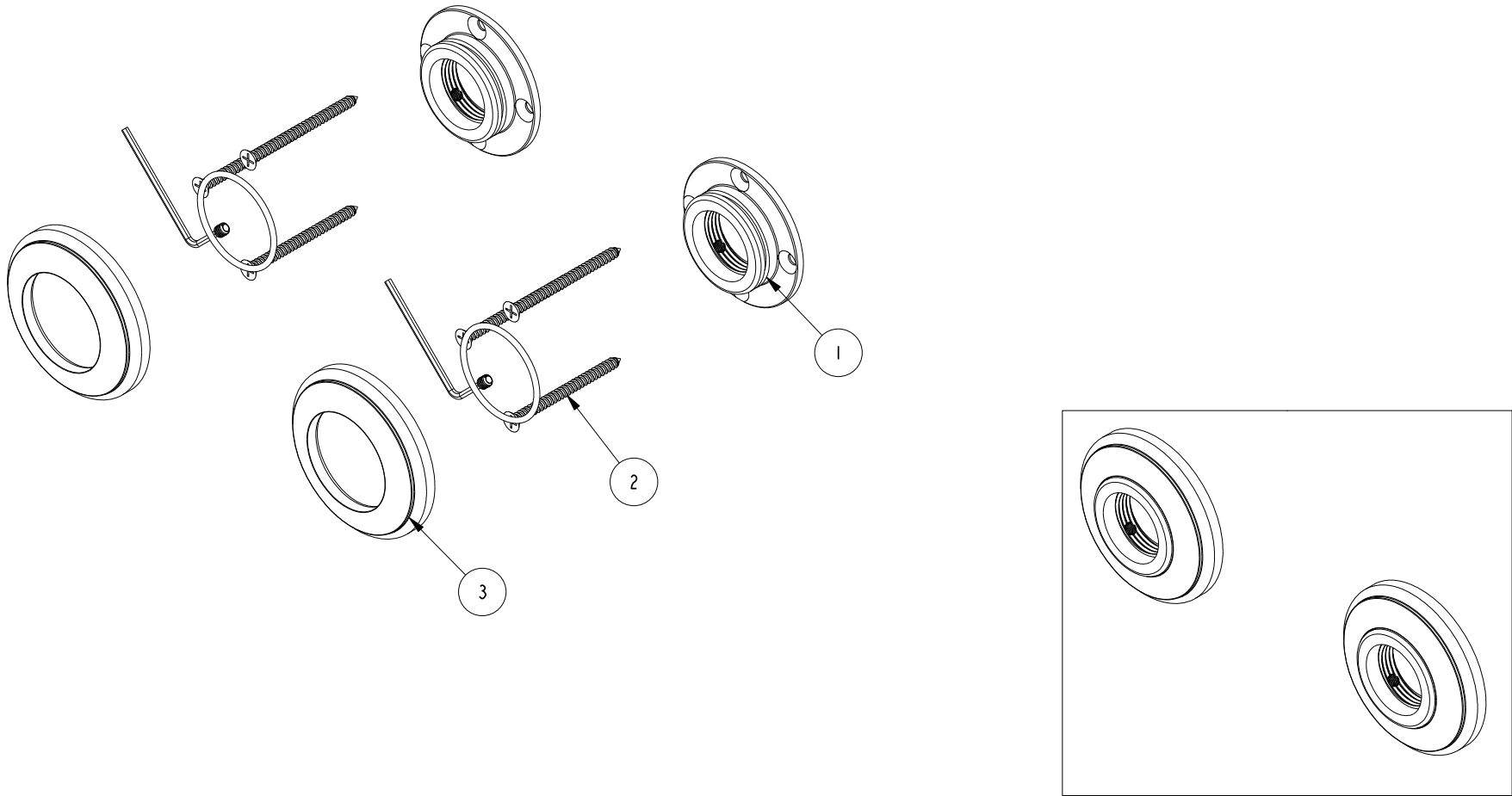

| ZONE | REV | DESCRIPTION | DATE | APPROVED |
|------|-----|-------------|----------|----------|
| - | - | EN-4575 | 11/02/22 | J.M. |

COPYRIGHT 2005 BRASSTECH, INC. THESE DRAWINGS AND THE DESIGNS DEPICTED HEREIN ARE THE PROPRIETARY PROPERTY OF BRASSTECH. ANY USE OR REPRODUCTION IS SUBJECT TO THE EXPRESS APPROVAL OF BRASSTECH. UNAUTHORIZED USE IS STRICTLY PROHIBITED. ALL RIGHTS RESERVED.

| TESTING | ASSEMBLY | PLATING | POLISHING | MACHINING | TOOLING FIXTURE # | APPLICATION |
|---------|----------|---------|-----------|-----------|-------------------|----------------------------------|
| - | - | - | - | - | - | REMOVE ALL BURRS AND SHARP EDGES |
| - | - | - | - | - | NEXT ASSY | USED ON |

| UNITS ARE: INCHES [MM] | TOLERANCES ARE: |
|--------------------------------|---|
| FRACTIONS DECIMALS ANGLES | $\pm 1/16"$.X $\pm .1$ [2.5] $\pm 1^\circ$ |
| | .XX $\pm .06$ [1.5] |
| (X.XXX) DENOTES CRITICAL DIMS. | |
| ALL THREADS ARE CRITICAL | |
| DRAWN | R.S. 11/02/22 |
| CHECKED | J.M. 11/02/22 |
| APPROVED | J.M. 11/02/22 |

BRASSTECH 2001 CARNEGIE AVE. SANTA ANA, CA 92705 (949) 417-5207
 INCORPORATED

GRAB BAR ESCUTECEON MOUNTING KIT

DWG NO. **2440-2400** REV -

SCALE .375 REF. - SHEET | OF 2

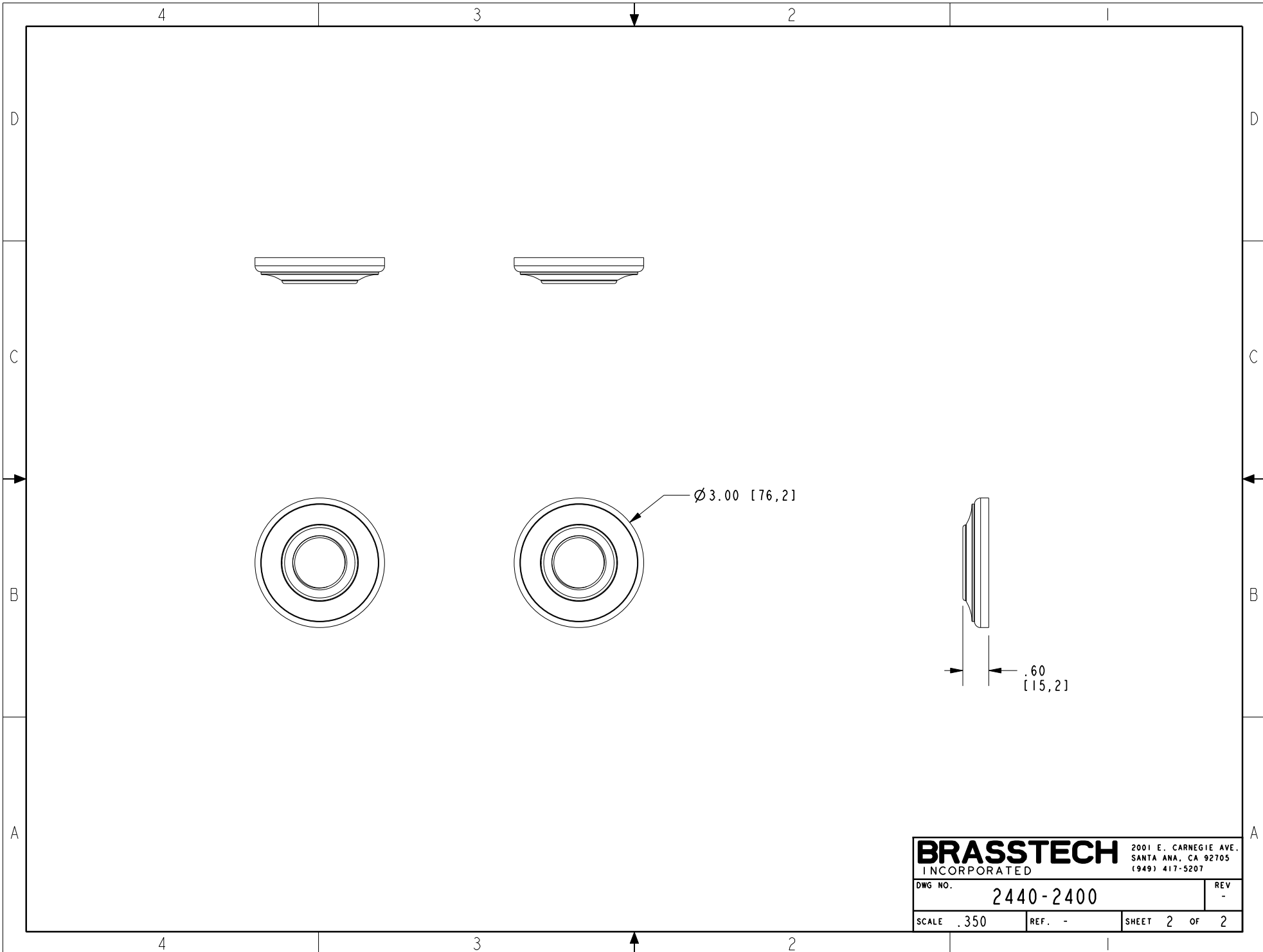

| | | | |
|------------------|-----------|--|--------|
| BRASSTECH | | 2001 E. CARNEGIE AVE. SANTA ANA, CA 92705 (949) 417-5207 | |
| DWG NO. | 2440-2400 | REV | - |
| SCALE | .350 | REF. | - |
| | | SHEET | 2 OF 2 |