

NOTES:

- (N1) 1. RAW METAL PARTS SHALL BE PURCHASED EXTERIOR POLISHED AND BUFFED.  
FOR MATERIAL SPECIFICATIONS SEE PS-E.001.  
FOR FINISH SPECIFICATIONS SEE SOP-Q.001 AND PS-Q.007
- (N2) 2. UNDIMENSIONED PART FEATURES SHALL COMPLY WITH 3D CAD DATA TO MAINTAIN DESIGN INTENT.
- 3. AESTHETIC DIMENSION SHALL COMPLY WITH PS-E.002 TO MAINTAIN DESIGN INTENT.
- (N4) 4. THREAD MASKING SHALL COMPLY WITH SOP-F.002.
- (N5) 5.  $\longleftrightarrow$  INDICATES STROKE DIRECTION FOR SATIN FINISHES ONLY.
- 6. DO NOT POLISH THIS SURFACE.
- 7. MASK THIS SURFACE PRIOR TO COPPERPLATE, POWDER COAT OR LACQUER.
- (N8) 8. BRAZING SHALL FOLLOW PS-E.001.

**BILL OF MATERIAL (CURRENT LEVEL)**

ITEM	PT/ASSY	DESCRIPTION	TYPE	QTY.
1	8-224	24" TOWEL SHELF FRAME W/ T BAR	ASSEMBLY	1
2	40629	TOWEL SHELF SLEEVE	PART	2

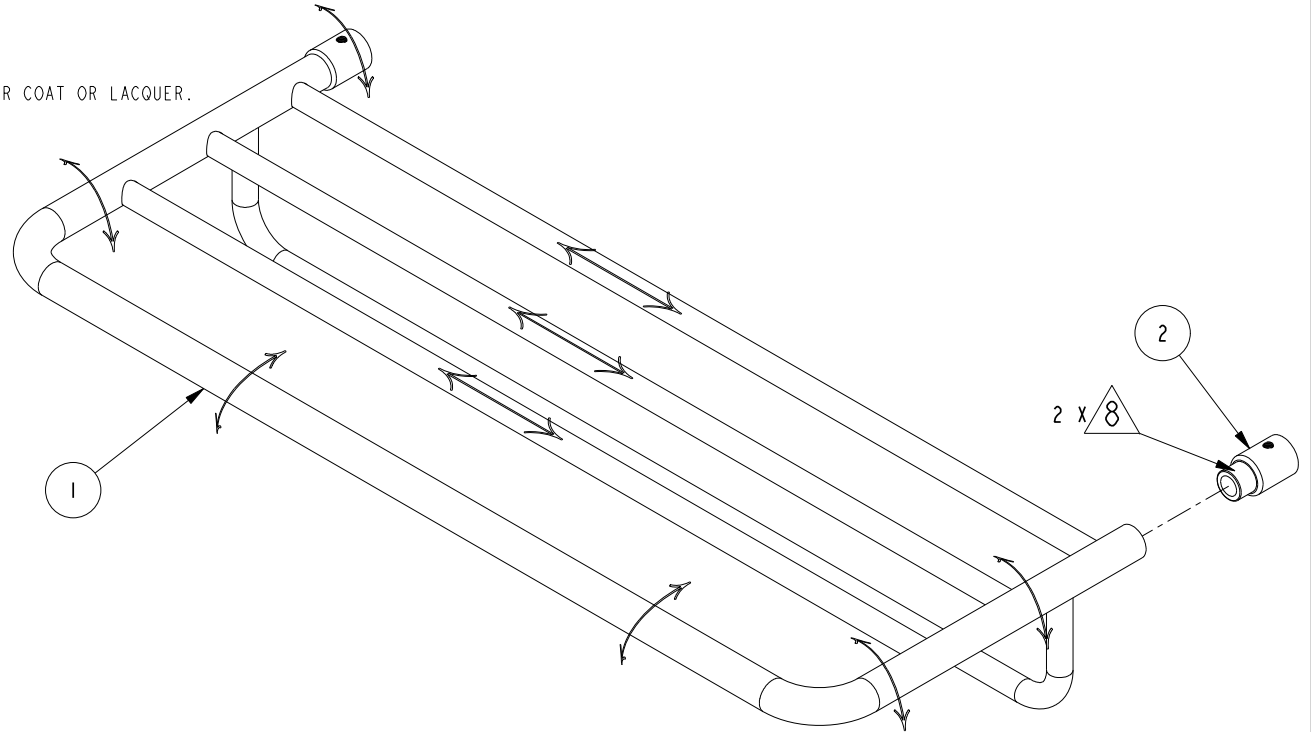

COPYRIGHT 2005 BRASSTECH, INC.  
THESE DRAWINGS AND THE DESIGNS  
DEPICTED HEREIN ARE THE PROPRIETARY  
PROPERTY OF BRASSTECH. ANY USE  
OR REPRODUCTION IS SUBJECT TO  
THE EXPRESS APPROVAL OF BRASSTECH.  
UNAUTHORIZED USE IS STRICTLY  
PROHIBITED. ALL RIGHTS RESERVED.

TESTING	-	-	-
ASSEMBLY	-	NEXT ASSY	USED ON
PLATING	-	APPLICATION	
POLISHING	-	REMOVE ALL BURRS AND SHARP EDGES	
MACHINING	-	MATERIAL BRASS - SEE NOTE 1	
TOOLING FIXTURE #		FINISH BRASS - SEE NOTE 1	

UNITS ARE: INCHES [MM]	
TOLERANCES ARE:	
FRACTIONS	DECIMALS
$\pm 1/16"$	$\pm .005$
ANGLES $\pm 1^\circ$	
.X $\pm$ .1 [2,5]	
.XX $\pm$ .06 [1,5]	
(X.XXX) DENOTES CRITICAL DIMS.	
ALL THREADS ARE CRITICAL	
DRAWN	R.S. 01/13/16
CHECKED	J.M. 01/13/16
APPROVED	J.M. 01/13/16

**BRASSTECH** 2001 CARNEGIE AVE.  
INCORPORATED SANTA ANA, CA 92705  
(949) 417-5207

24" HOTEL SHELF FRAME W/  
T BAR

DWG NO. **XX43-24** REV A

SCALE .187 REF. - SHEET 1 OF 2

-	A	EN-2949	01/13/16	J.M.
ZONE	REV	DESCRIPTION	DATE	APPROVED

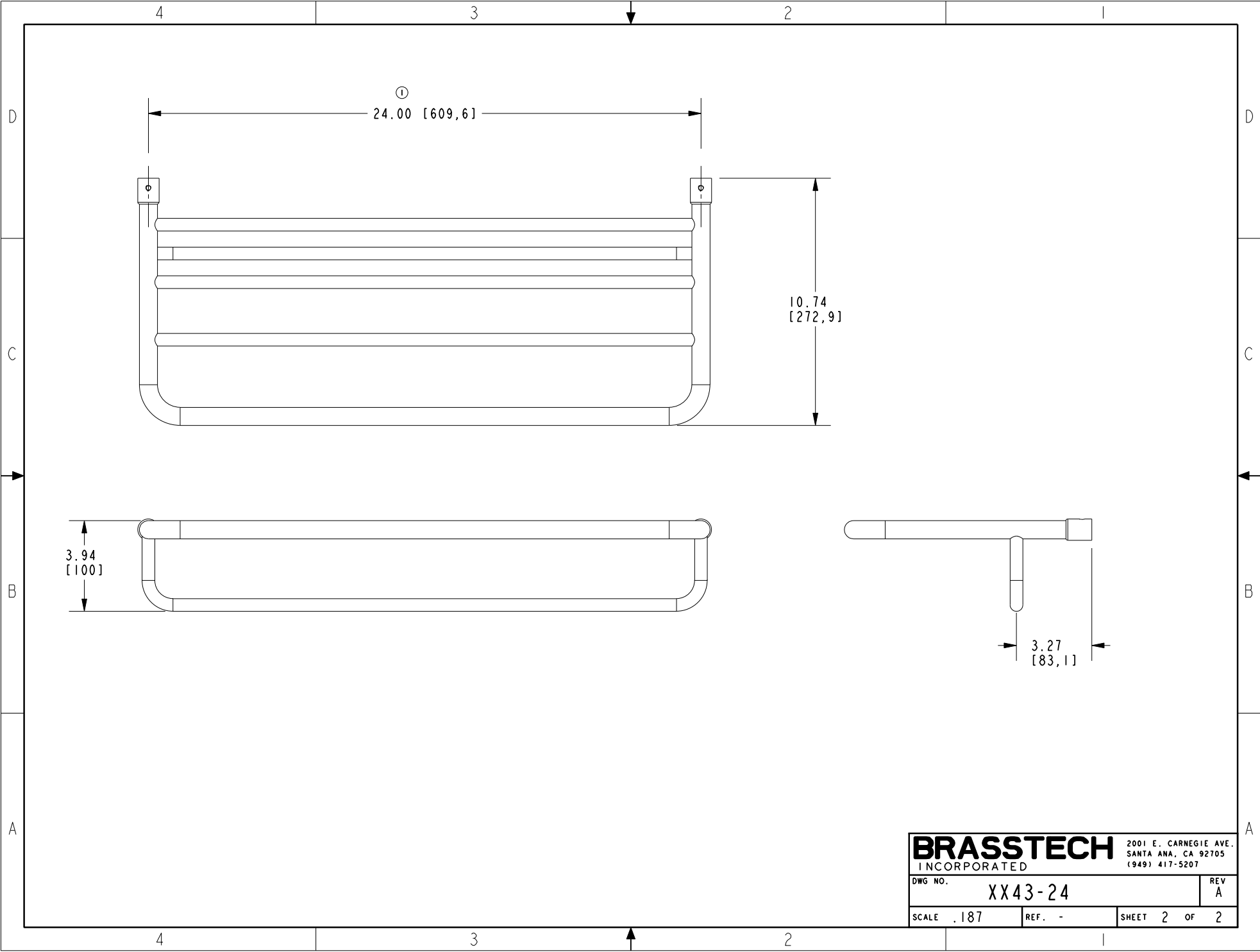

<b>BRASSTECH</b>		2001 E. CARNEGIE AVE.	
INCORPORATED		SANTA ANA, CA 92705	
		(949) 417-5207	
DWG NO.	XX43-24	REV	A
SCALE .187	REF. -	SHEET 2	OF 2