

NOTES:

1. TO INSPECT ASSEMBLY, FOLLOW FIRST ARTICLE AND IN PROCESS INSPECTION SHEET.

2 APPLY DOW CORNING 111

3 APPLY LOCTITE 680

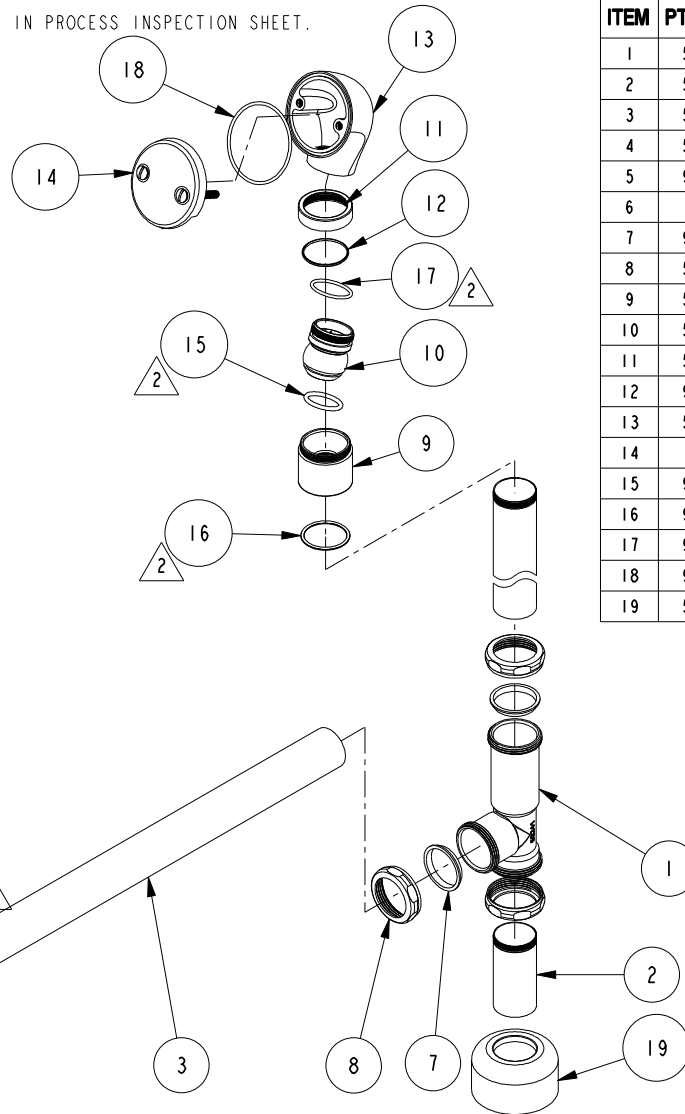

BILL OF MATERIAL (CURRENT LEVEL)

ITEM	PT/ASSY	DESCRIPTION	TYPE	QTY.
1	50241	WASHER TEE	PART	1
2	50242	TUBE, 1-1/2" X 3" X .040"	PART	1
3	50244	TUBE OVf 1.5 X 18 X .040	PART	2
4	50238	WASTE CAST'G 1-1/2	PART	1
5	91170	WASHER	PART	1
6	270	LIFT & TURN BATH PLUG	ASSEMBLY	1
7	91169	WSHR, 1.50 ID X 1.73 OD X .25 THK.	PART	2
8	50243	NUT SLIP JOINT 1-1/2	PART	3
9	51058	SOCKET - WASTE OVERFLOW	PART	1
10	51060	BALL JOINT - WASTE OVERFLOW	PART	1
11	51059	SCREW CAP - WASTE OVERFLOW	PART	1
12	91784	PLASTIC WASHER	PART	1
13	51061	DECORATIVE OVERFLOW HEAD	PART	1
14	266	W/O FACEPLATE W/2 SCRWs	ASSEMBLY	1
15	91631	O-RING, #2-216, EPDM, 65-75 DURO	PART	1
16	91256	O-RING, #2-128, EPDM, 65-75 DURO	PART	1
17	91227	O-RING, #2-125, EPDM, 65-75 DURO	PART	1
18	91547	O-RING, #2-147, EPDM, 65-75 DURO	PART	1
19	50839	HIGH BOX FLANGE (313)	PART	1

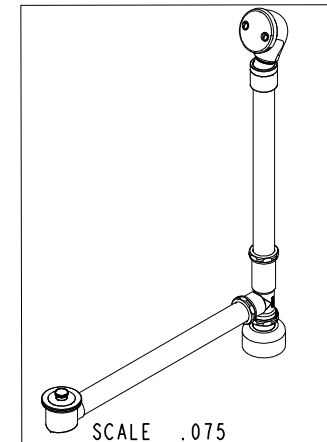

ZONE	REV	DESCRIPTION	DATE	APPROVED
-	C	EN-4300ii	10/11/21	R. S.
-	B	EN-4348	05/17/21	C. G.
-	A	EN-4138	03/13/20	J. M.
-	-	EN-3838	03/28/19	J. M.

COPYRIGHT 2005 BRASSTECH, INC. THESE DRAWINGS AND THE DESIGNS DEPICTED HEREIN ARE THE PROPRIETARY PROPERTY OF BRASSTECH. ANY USE OR REPRODUCTION IS SUBJECT TO THE EXPRESS APPROVAL OF BRASSTECH. UNAUTHORIZED USE IS STRICTLY PROHIBITED. ALL RIGHTS RESERVED.

TESTING	-	-	-
ASSEMBLY	-	-	-
PLATING	-	-	-
POLISHING	-	NEXT ASSY	USED ON
MACHINING	-	APPLICATION	
TOOLING FIXTURE #	REMOVE ALL BURRS AND SHARP EDGES		

UNITS ARE: INCHES [MM]	
TOLERANCES ARE:	
FRACTIONS	DECIMALS
±1/16"	±.005
.X ±.1	[2.5]
.XX ±.06	[1.5]
(X.XXX) DENOTES CRITICAL DIMS.	
ALL THREADS ARE CRITICAL	
DRAWN	G.B.
03/22/19	
CHECKED	-
APPROVED	-

BRASSTECH 2001 CARNEGIE AVE.
INCORPORATED SANTA ANA, CA 92705
(949) 417-5207

PIVOTING LIFT & TURN OVERFLOW

DWG NO. 111-2961 REV C

SCALE .150 REF. - SHEET 1 OF 2

