

NOTES:

1. TO INSPECT ASSEMBLY, FOLLOW FIRST ARTICLE AND IN PROCESS INSPECTION SHEET.

2. APPLY PERMANENT THREAD LOCKER (LOCTITE 680)

**BILL OF MATERIAL (CURRENT LEVEL)**

ITEM	PT/ASSY	DESCRIPTION	TYPE	QTY.
1	6XXB	MOUNTING BRACKET	PART	1
2	1-206	HARDWARE PACK	ASSEMBLY	1
3	600B	HEX CONE - SMALL	PART	1
4	40814	POST - OPEN TOWEL RING	PART	1
5	40757	HANGING TISSUE BAR	PART	1
6	92423	SCRW, 8-32 X 5/16 SKT HD CUP PT W/ SELF LOC SS	PART	1
7	91578	O-RING, 2 X 6MM ID, EPDM, 65-75 DURO	PART	2
8	40754	FINIAL	PART	1
9	92308	SCRW, M5 X 5 SKT HD CUP PT W/ SELF LOC SS	PART	1
10	10888	HEX KEY, 2.5MM ALLOY STEEL	PART	1

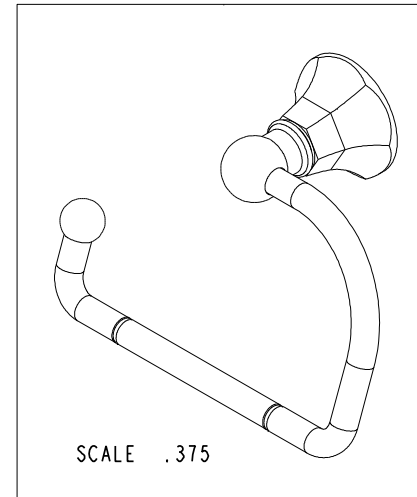
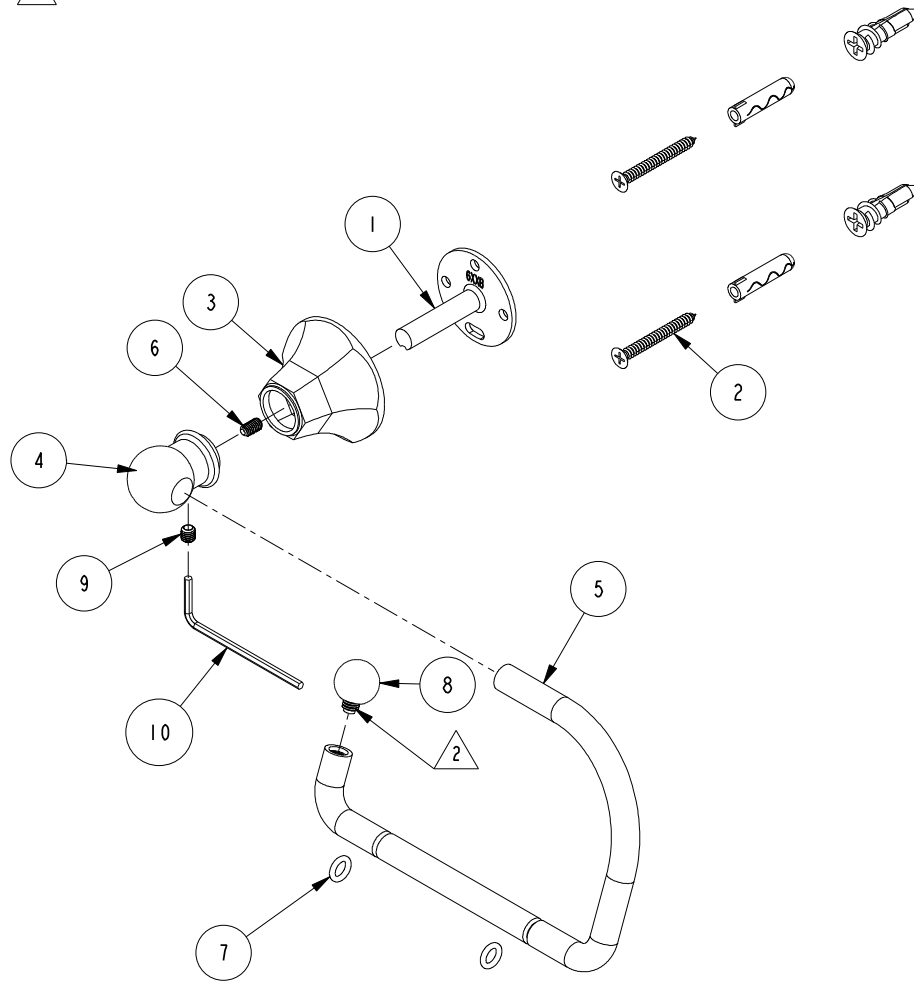

ZONE	REV	DESCRIPTION	DATE	APPROVED	TESTING	ASSEMBLY	PLATING	POLISHING	MACHINING	TOOLING FIXTURE #	APPLICATION
-	A	EN-4358	02/07/22	R. S.	-	-	-	-	-	-	-
-	-	EN-3913	08/15/19	J. M.	-	-	-	-	-	-	USED ON
-	-	-	-	-	-	-	-	-	-	-	REMOVE ALL BURRS AND SHARP EDGES

COPYRIGHT 2005 BRASSTECH, INC. THESE DRAWINGS AND THE DESIGNS DEPICTED HEREIN ARE THE PROPRIETARY PROPERTY OF BRASSTECH. ANY USE OR REPRODUCTION IS SUBJECT TO THE EXPRESS APPROVAL OF BRASSTECH. UNAUTHORIZED USE IS STRICTLY PROHIBITED. ALL RIGHTS RESERVED.

UNITS ARE: INCHES [MM]	
FRACTIONS	DECIMALS
±1/16"	.X ±.1 [2.5]
	.XX ±.06 [1.5]
ANGLES	
	±1°
(X.XXX) DENOTES CRITICAL DIMS. ALL THREADS ARE CRITICAL	
DRAWN	R.S. 08/15/19
CHECKED	J.M. 08/15/19
APPROVED	J.M. 08/15/19

**BRASSTECH** 2001 CARNEGIE AVE. SANTA ANA, CA 92705 (949) 417-5207  
INCORPORATED

**HANGING TT HOLDER**

DWG NO.	1200-1510	REV	A
SCALE	.375	REF.	-
SHEET	1	OF	2

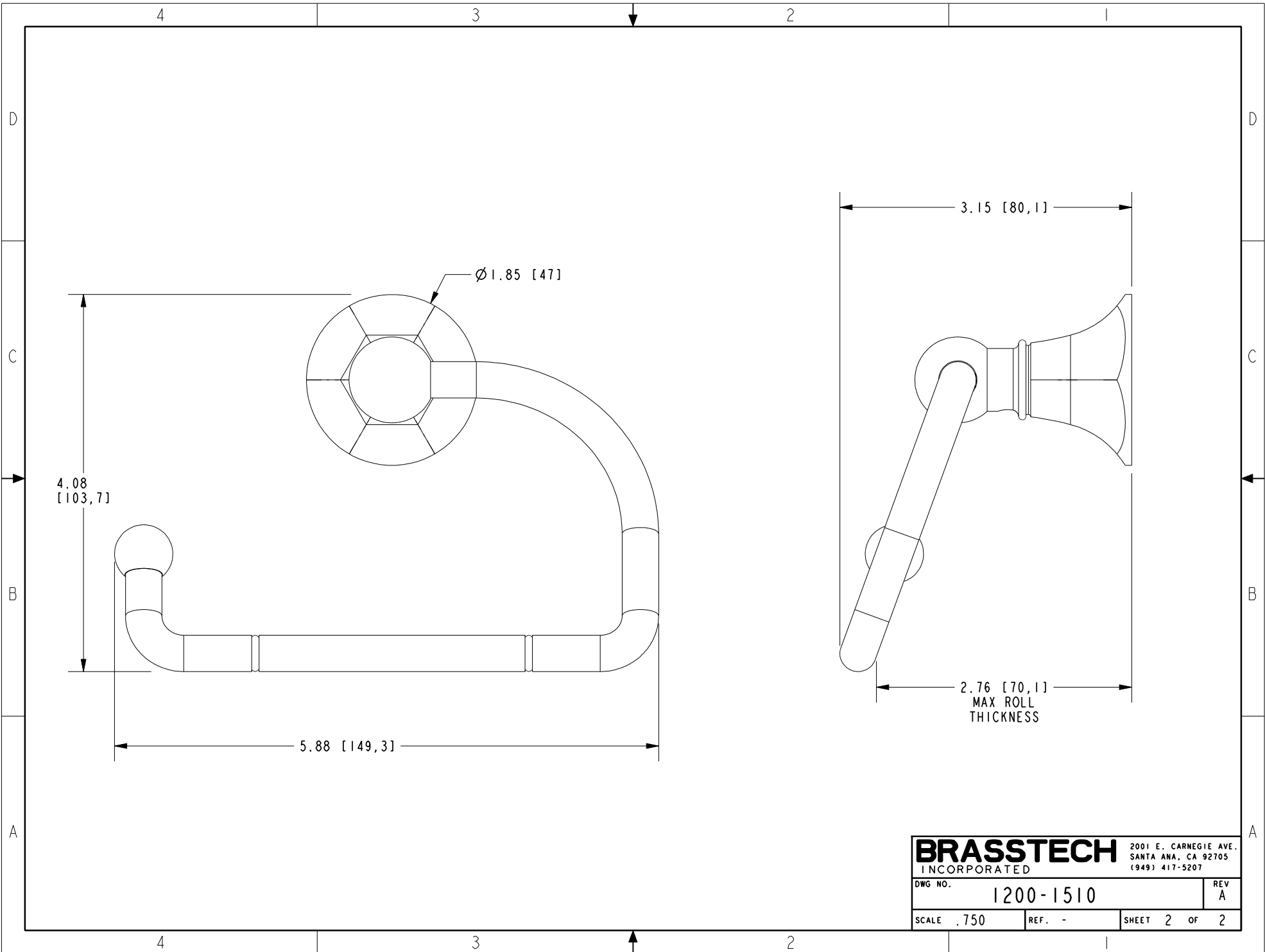

<b>BRASSTECH</b>		2001 E. CARNEGIE AVE. SANTA ANA, CA 92705 (949) 417-5207	
DWG NO.	1200-1510	REV	A
SCALE	.750	REF.	-
SHEET 2		OF 2	