

NOTES:

1. TO INSPECT ASSEMBLY, FOLLOW FIRST ARTICLE AND IN PROCESS INSPECTION SHEET.

2. APPLY LOCTITE 680.

3. APPLY 3M SCOTCH-WELD DP-100NS OR EQUIVALENT.

N4 4. TIGHTEN THE NUT 13112 IN THE WAY THAT IT WILL TAKE 20-25 LB-IN TORQUE TO MOVE THE PIVOT BALL.

5. APPLY THIN FILM OF DOW CORNING 111.

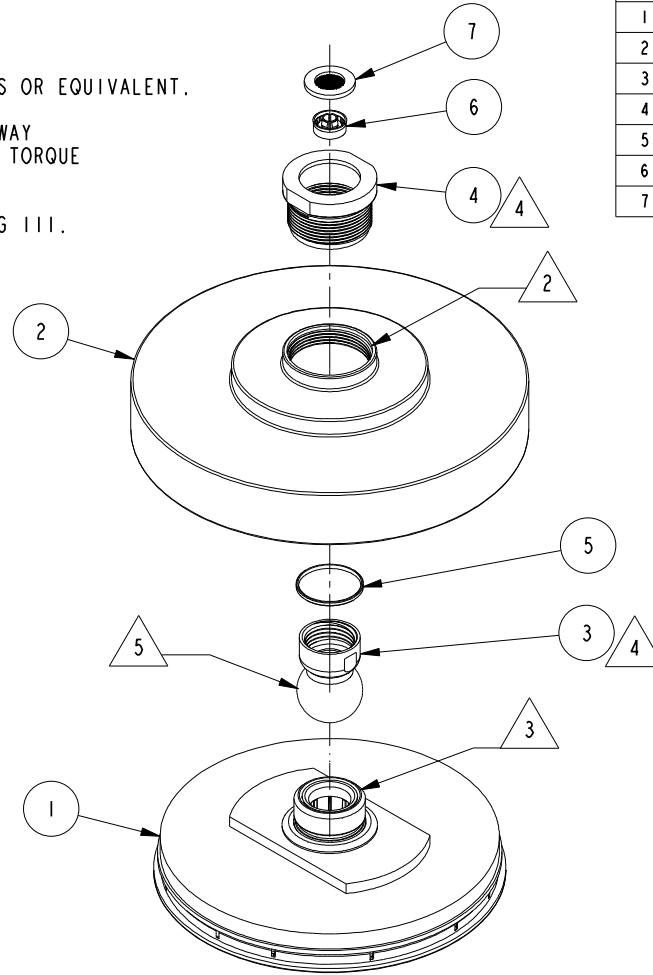

BILL OF MATERIAL (CURRENT LEVEL)

ITEM	PT/ASSY	DESCRIPTION	TYPE	QTY.
1	5-065	SHOWER ENGINE - 3 JET	ASSEMBLY	1
2	80222	SHOWER ENGINE SHELL	PART	1
3	80018	PIVOT BALL	PART	1
4	13112	SHOWER COLLAR NUT	PART	1
5	91157	WSHR, .920 ID X 1.0 OD X .066 THK, FLT, NYLON	PART	1
6	12833	FLOW REGULATOR, 1.8 GPM MAX	PART	1
7	91606	GASKET W/ FILTER SCREEN	PART	1

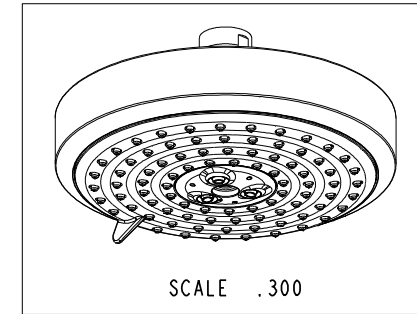

-	F	EN-4300w	03/12/21	R.S.
-	E	EN-3999	10/17/19	C.G.
-	D	EN-3732	12/05/18	C.G.
-	C	EN-3552	03/20/18	V.V.
-	B	EN-3410	12/29/17	C.G.
-	A	EN-1668	04/05/11	-
-	-	EQ-0894	10/18/07	-
ZONE	REV	DESCRIPTION	DATE	APPROVED

COPYRIGHT 2005 BRASSTECH, INC. THESE DRAWINGS AND THE DESIGNS DEPICTED HEREIN ARE THE PROPRIETARY PROPERTY OF BRASSTECH. ANY USE OR REPRODUCTION IS SUBJECT TO THE EXPRESS APPROVAL OF BRASSTECH. UNAUTHORIZED USE IS STRICTLY PROHIBITED. ALL RIGHTS RESERVED.

TESTING	-	-	-
ASSEMBLY	-	-	-
PLATING	-	3-2482BP	3-2482BP
POLISHING	-	NEXT ASSY	USED ON
MACHINING	-	APPLICATION	
TOOLING FIXTURE #	REMOVE ALL BURRS AND SHARP EDGES		

UNITS ARE: INCHES [MM]	
TOLERANCES ARE:	
FRACTIONS	DECIMALS
±1/16"	.X ±.1 [2.5]
	.XX ±.06 [1.5]
ANGLES ±1°	
(X.XXX) DENOTES CRITICAL DIMS.	
ALL THREADS ARE CRITICAL	
DRAWN	MANJUNATH 10/17/19
CHECKED	C.G. 10/17/19
APPROVED	C.G. 10/17/19

BRASSTECH		2001 CARNEGIE AVE. SANTA ANA, CA 92705 (949) 417-5207	
INCORPORATED			
CONTEMP. SHOWER HEAD - 5 JETS			
DWG NO.	2143	REV	F
SCALE	.350	REF.	-
SHEET	1	OF	2

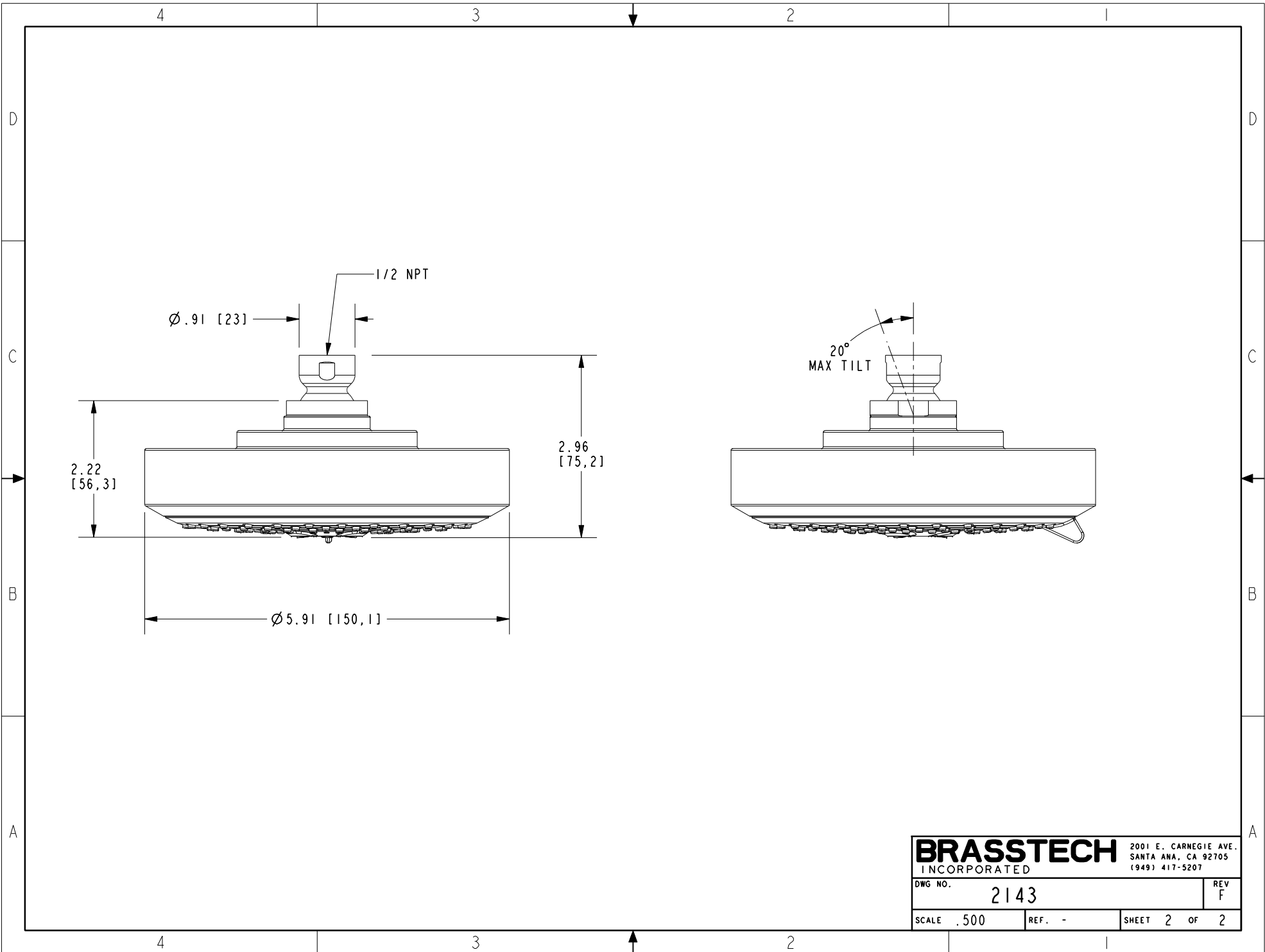

BRASSTECH		2001 E. CARNEGIE AVE. SANTA ANA, CA 92705 (949) 417-5207	
DWG NO.	2143	REV	F
SCALE	.500	REF.	-
		SHEET	2 OF 2