

NOTES:

1. TO INSPECT ASSEMBLY, FOLLOW FIRST ARTICLE AND IN PROCESS INSPECTION SHEET.
2. APPLY LOCTITE 680.
3. CUT AND SHORTEN O-RING BY .13" TO .20" IN LENGTH BEFORE INSTALLING.
4. SLIT O-RING BEFORE INSTALLING.
5. APPLY LOCTITE 242.
6. CONNECT WHITE AND RED TUBINGS TOGETHER AND WATER TEST WHOLE UNIT.
7. BAG 92194 IN A SEPARATE BAG.
8. REWORK CARTRIDGE ASSY IF THE HANDLE DOES NOT RETURN TO THE 'OFF' POSITION AUTOMATICALLY AFTER WATER TESTING.
9. INSTALLATION TORQUE: 8-14 LB-FT.
10. INSTALLATION TORQUE: 78 LB-IN +/- 6 LB-IN.
11. LUBRICATE SPRING WITH DOW CORNING III SILICONE COMPOUND.
12. APPLY LIGHT FILM OF DOW CORNING III SILICONE COMPOUND.
13. INSTALLATION TORQUE: 10 -14 LB-IN.

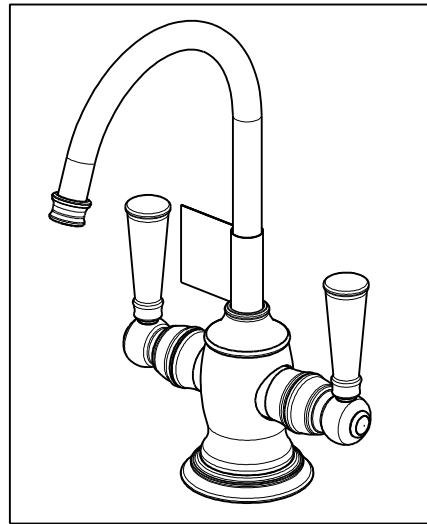

BILL OF MATERIAL (CURRENT LEVEL)

ITEM	PT/ASSY	DESCRIPTION	TYPE	QTY.
1	1-134	CARTR 3/8 HOT 1/4 TR	PART	1
2	1-393	1-1/8 18 UNEF MOUNTING KIT	ASSEMBLY	1
3	1-431	RED SUPPLY LINE	ASSEMBLY	1
4	1-432	BLUE SUPPLY LINE	ASSEMBLY	1
5	1-433	GREY SUPPLY LINE	ASSEMBLY	1
6	5-067	3/8 SELF CLOSING CART. ASM.	ASSEMBLY	1
7	11731	ESCUTCHEON	PART	1
8	11733	SHELL, SPOUT, WATER DISP	PART	1
9	13070	RETAINER PLATE	PART	1
10	13289	NIPPLE	PART	1
11	13606	WATER DISP. BODY H/C (TRAD)	PART	1
12	13680	BODY HANDLE	PART	2
13	13681	CAP. BODY, WATER DISP	PART	1
14	13682	BONNET	PART	2
15	13785	LEVER, HANDLE	PART	2
16	50713	SPOUT, WATER DISP. (TRAD.)	PART	1
17	91017	O-RING #2-012	PART	2
18	91023	O-RING, #2- 019, EPDM, 65-75 DURO, NSF 61	PART	1
19	91372	O-RING, #2- 021, EPDM, 65-75 DURO, NSF 61	PART	1
20	91382	O-RING, #2- 012, TEFLON,	PART	1
21	91383	O-RING, #2- 014, TEFLON, NSF 61	PART	1
22	91762	O-RING, #2-132, EP, 50 DURO - GREY	PART	1
23	92016	SCRW, 10-24 X 3/4 SKT HD FLT PT SS	PART	1
24	92017	SCRW, 1/4-20 X 3/16 SKT HD CUP PT SS	PART	2
25	92194	COUPLING, 3/8" X 1/4"	PART	1
26	92477	SCRW, M4 X 16 SKT FLT HD SS	PART	1
27	92926	ADAPTER	PART	1
28	98043	TAG LABEL, HOT WATER WARNING	PART	1

-	J	EN-4187	10/25/22	J.M.
-	G	EN-4300jj	04/12/21	R.S.
-	F	EN-3634A	11/21/19	C.G.
-	E	EN-3722	02/08/19	C.G.
-	D	EN-3558o	01/01/19	V.V.
-	C	EN-3312	05/15/17	J.A
-	B	EN-3272	02/28/17	N.S.
-	A	EN-2601	10/10/13	-
-	-	EN-2576	08/02/13	-
ZONE	REV	DESCRIPTION	DATE	APPROVED

COPYRIGHT 2005 BRASSTECH, INC. THESE DRAWINGS AND THE DESIGNS DEPICTED HEREIN ARE THE PROPRIETARY PROPERTY OF BRASSTECH. ANY USE OR REPRODUCTION IS SUBJECT TO THE EXPRESS APPROVAL OF BRASSTECH. UNAUTHORIZED USE IS STRICTLY PROHIBITED. ALL RIGHTS RESERVED.

TESTING	-	-	-
ASSEMBLY	-	-	-
PLATING	-	-	-
POLISHING	-	NEXT ASSY	USED ON
MACHINING	-	APPLICATION	
TOOLING FIXTURE #		REMOVE ALL BURRS AND SHARP EDGES	

UNITS ARE: INCHES [MM]
TOLERANCES ARE:
FRACTIONS DECIMALS ANGLES
±1/16" .X ±.1 [2.5] ±1°
.XX ±.06 [1.5]

(X.XXX) DENOTES CRITICAL DIMS.
ALL THREADS ARE CRITICAL

DRAWN	JINSON	10/25/22
CHECKED	G.B.	10/25/22
APPROVED	J.M.	10/25/22

BRASSTECH 2001 CARNEGIE AVE.
INCORPORATED SANTA ANA, CA 92705
(949) 417-5207

H & C WATER DISPENSER

DWG NO. **2470-5603** REV **J**

SCALE .300 REF. - SHEET 1 OF 3

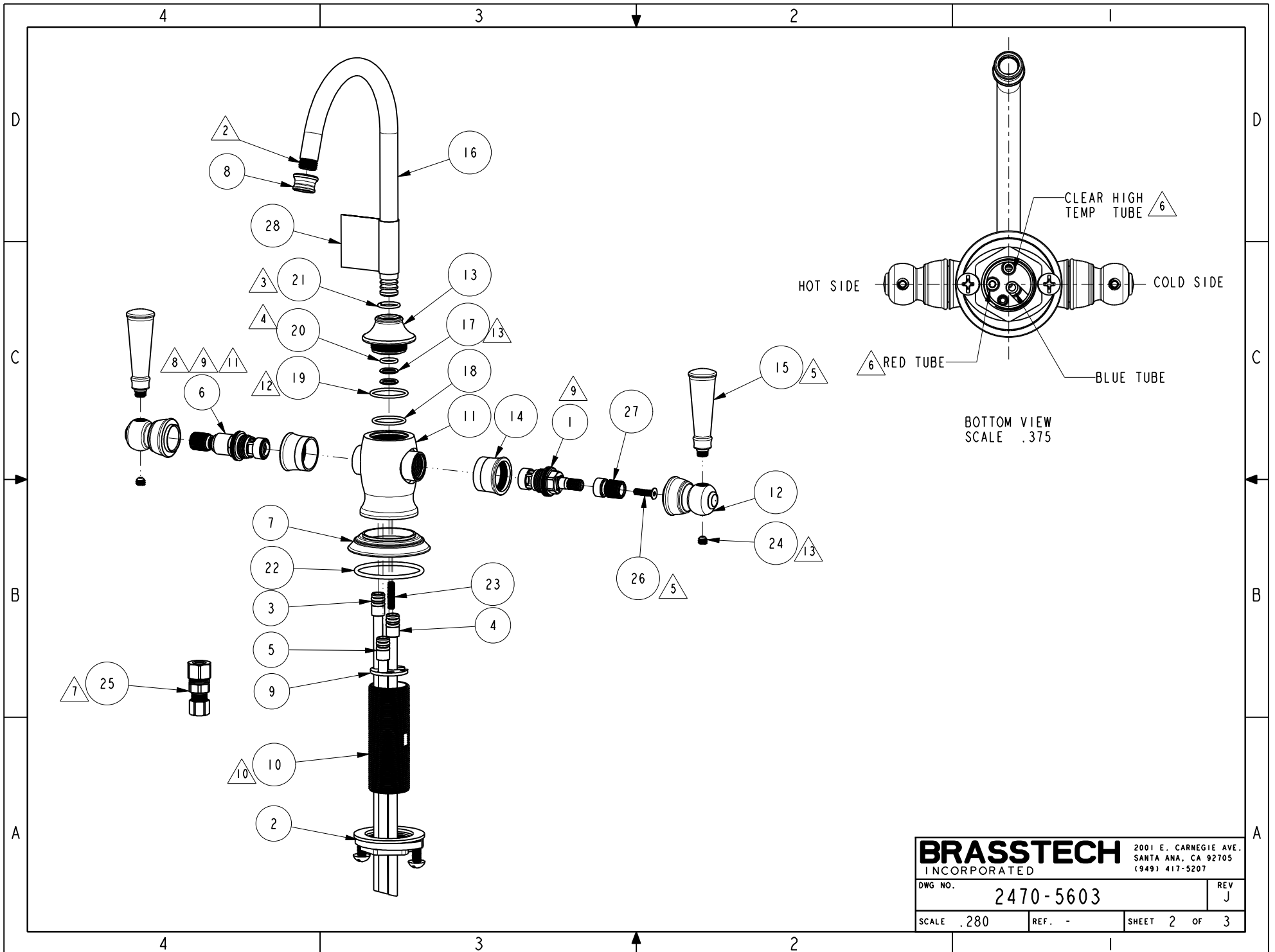

BRASSTECH		2001 E. CARNEGIE AVE. SANTA ANA, CA 92705 (949) 417-5207
DWG NO.	2470-5603	REV J
SCALE .280	REF. -	SHEET 2 OF 3

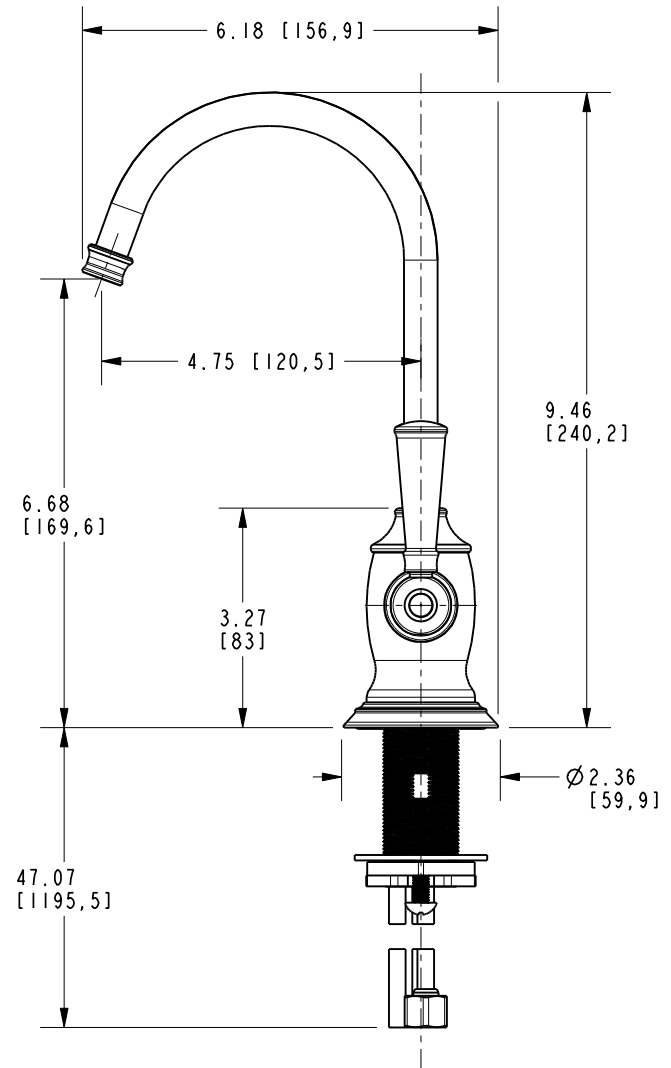
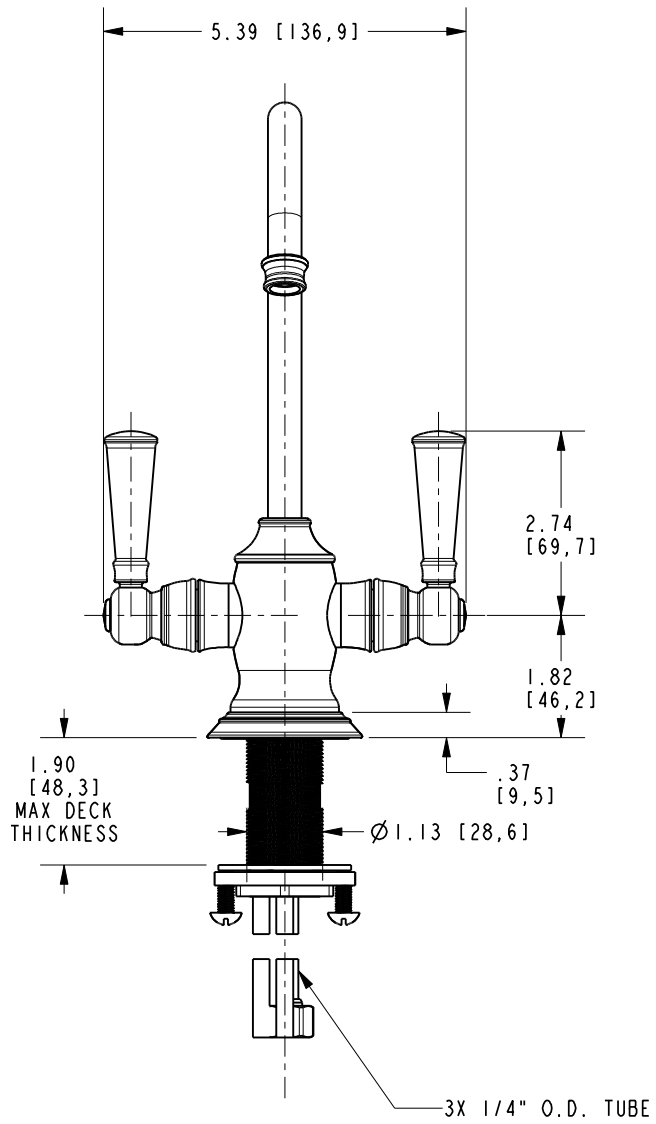

BRASSTECH		2001 E. CARNEGIE AVE. SANTA ANA, CA 92705 (949) 417-5207	
DWG NO.	2470-5603	REV	J
SCALE	.350	REF.	-
		SHEET	3 OF 3