

NOTES:

- (N1) 1. TO INSPECT ASSEMBLY, FOLLOW FIRST ARTICLE AND IN PROCESS INSPECTION SHEET.

BILL OF MATERIAL (CURRENT LEVEL)

| ITEM | PT/ASSY | DESCRIPTION | TYPE | QTY. |
|------|---------|--------------------------------|----------|------|
| 1 | 3-719 | SPOUT ASM | ASSEMBLY | 1 |
| 2 | 3-368 | HANDLE AND ESCUTCHEON ASSEMBLY | ASSEMBLY | 2 |
| 3 | 80030 | POP UP KNOB | PART | 1 |
| 4 | 1-676 | W/S VALVE INSTALLATION | ASSEMBLY | 1 |
| 5 | 10288 | 3/16" POP UP ROD | PART | 1 |
| 6 | 325 | POP UP ASSEMBLY | ASSEMBLY | 1 |

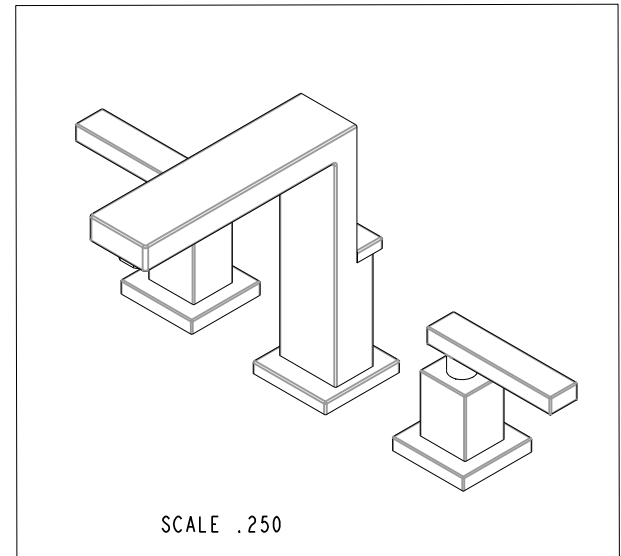
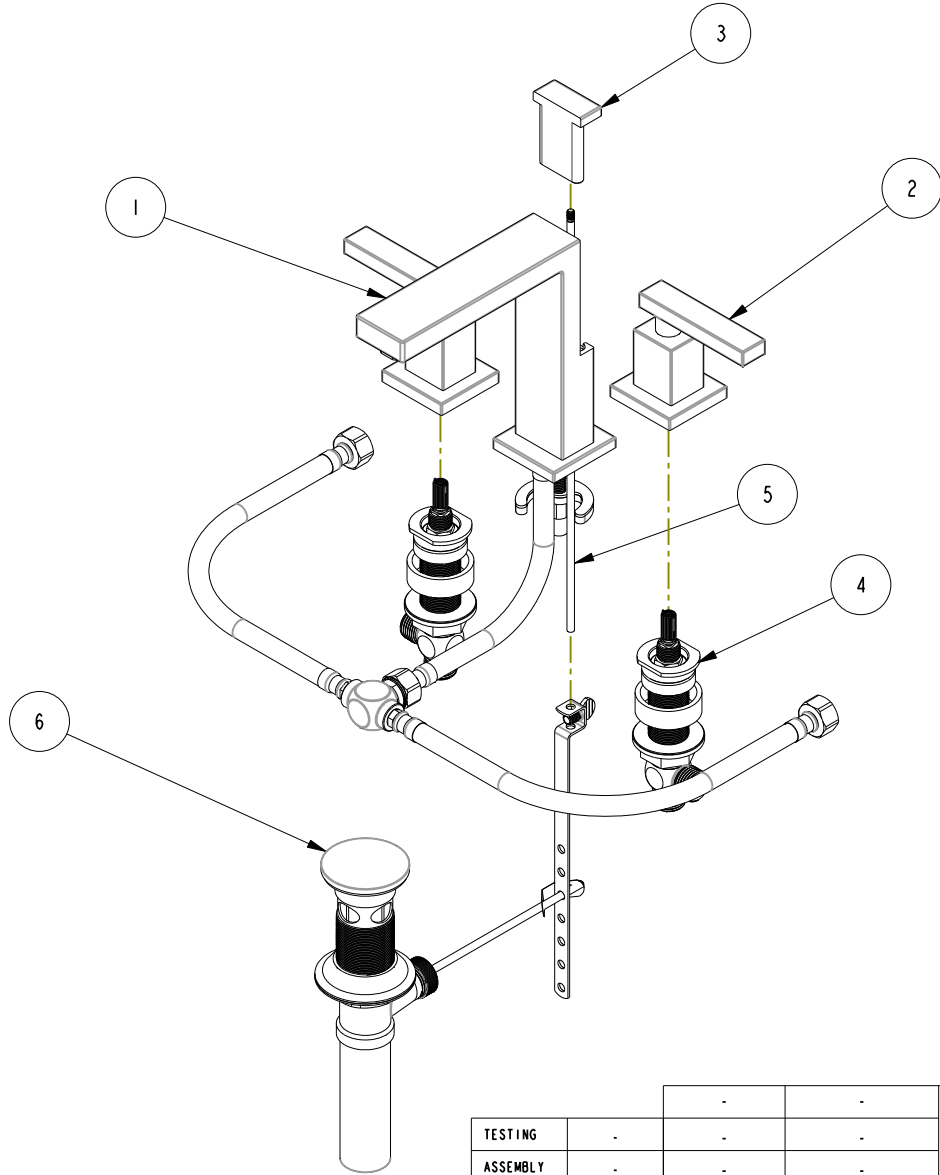

| | | | |
|-------------------|----------------------------------|-------------|---------|
| TESTING | - | - | - |
| ASSEMBLY | - | - | - |
| PLATING | - | - | - |
| POLISHING | - | NEXT ASSY | USED ON |
| MACHINING | - | APPLICATION | |
| TOOLING FIXTURE # | REMOVE ALL BURRS AND SHARP EDGES | | |

UNITS ARE: INCHES [MM]
 TOLERANCES ARE:
 FRACTIONS DECIMALS ANGLES
 $\pm 1/16"$.X $\pm .1$ [2.5] $\pm 1^\circ$
 .XX $\pm .06$ [1.5]
 (X.XXX) DENOTES CRITICAL DIMS.
 ALL THREADS ARE CRITICAL
 DRAWN HNS 10/14/20
 CHECKED W. SANTOS 10/14/20
 APPROVED W. SANTOS 10/14/20

BRASSTECH 2001 CARNEGIE AVE.
 INCORPORATED SANTA ANA, CA 92705
 (949) 417-5207

W/S LAV FAUCET

DWG NO. 2560C REV -
 SCALE .210 REF. - SHEET 1 OF 2

COPYRIGHT 2005 BRASSTECH, INC.
 THESE DRAWINGS AND THE DESIGNS
 DEPICTED HEREIN ARE THE PROPRIETARY
 PROPERTY OF BRASSTECH. ANY USE
 OR REPRODUCTION IS SUBJECT TO
 THE EXPRESS APPROVAL OF BRASSTECH.
 UNAUTHORIZED USE IS STRICTLY
 PROHIBITED. ALL RIGHTS RESERVED.

| EN-4204 | 10/14/20 | N.S. | | |
|---------|----------|-------------|------|----------|
| ZONE | REV | DESCRIPTION | DATE | APPROVED |

