



4

3

2

1

NOTES:

- (N1) 1. FIT / FORM / FUNCTION SHALL FOLLOW PS-E.008.
- (N2)  2 TORQUE REQUIRED TO TIGHTEN THE SCREWS 24-26 LB-IN
-  3 APPLY DOW CORNING 700 SILICONE TO SEAL MAGNETS FROM MOISTURE
- (4)  4 2-1 1/2 NPSM
EXT. MAJOR DIA. MAX. 2.332 MIN. 2.320
EXT. PITCH DIA. MAX. 2.275 MIN. 2.269

BILL OF MATERIAL (CURRENT LEVEL)

ITEM	PT/ASSY	DESCRIPTION	TYPE	QTY.
1	50969	6" SQUARE DRAIN THROAT	PART	1
2	50956	6" SQUARE DRAIN FLANGE	PART	1
3	92498	SCRW, 10-24 X 1/4 SKT BUTTON HD SS	PART	4
4	12803	4" DOME STRAINER	PART	1
5	50955	PROTECTIVE COVER 6"	PART	1

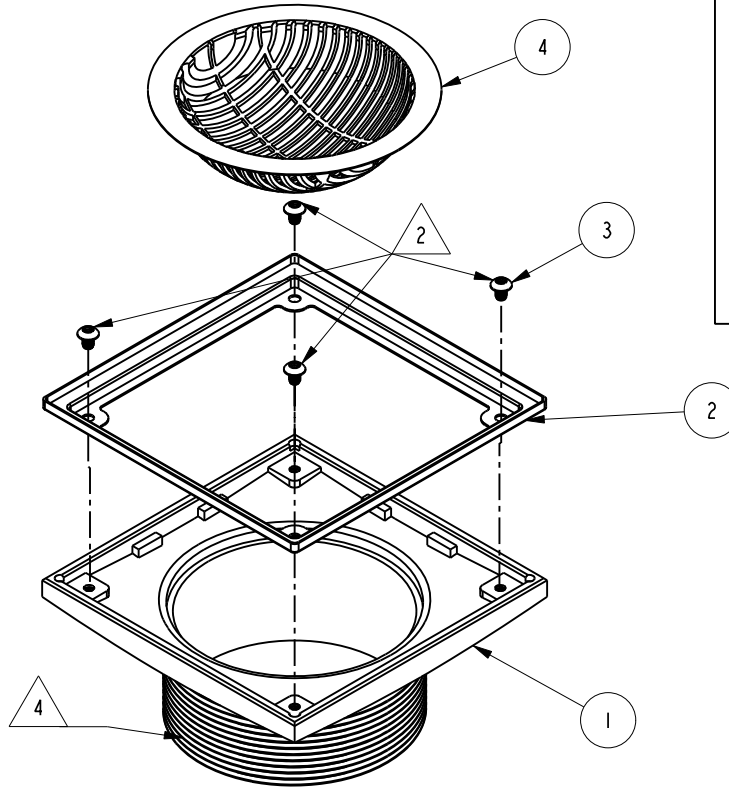
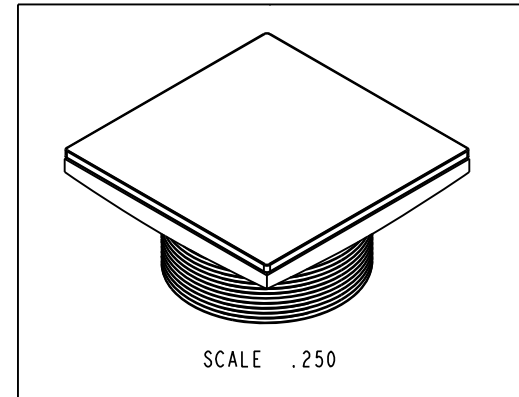
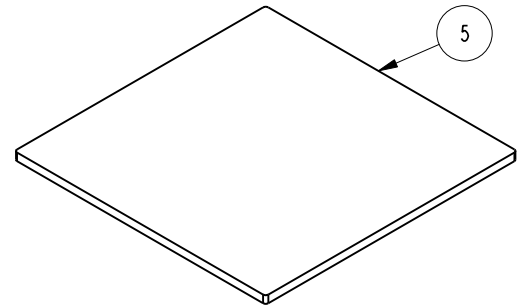

ZONE	REV	DESCRIPTION	DATE	APPROVED
-	J	EN-3863	05/20/19	J.M.
-	H	EN-3857	04/22/19	J.M.
-	G	EN-3370o	12/21/17	J.M.
-	F	EN-2854	12/31/15	J.M.
-	E	EN-2828	10/24/14	-
-	D	EN-2401	01/04/13	-
-	C	EN-2380	12/13/12	-
-	B	EN-2228	07/26/12	-
-	A	EN-2144	04/18/12	-
-	-	EN-1714	03/06/12	-

COPYRIGHT 2005 BRASSTECH, INC. THESE DRAWINGS AND THE DESIGNS DEPICTED HEREIN ARE THE PROPRIETARY PROPERTY OF BRASSTECH. ANY USE OR REPRODUCTION IS SUBJECT TO THE EXPRESS APPROVAL OF BRASSTECH. UNAUTHORIZED USE IS STRICTLY PROHIBITED. ALL RIGHTS RESERVED.

TESTING	ASSEMBLY	PLATING	POLISHING	MACHINING	TOOLING FIXTURE #
-	-	-	-	-	-
-	-	278-02	278-02	-	-
-	-	NEXT ASSY	USED ON	-	-
-	-	APPLICATION		-	-
-	-	REMOVE ALL BURRS AND SHARP EDGES		-	-

UNITS ARE: INCHES [MM]		
TOLERANCES ARE:		
FRACTIONS	DECIMALS	ANGLES
±1/16"	.X ±.1 [2.5]	±1°
	.XX ±.06 [1.5]	
(X.XXX) DENOTES CRITICAL DIMS. ALL THREADS ARE CRITICAL		
DRAWN	JINSON	12/31/15
CHECKED	RAVINDRA	12/31/15
APPROVED	J.M.	12/31/15

BRASSTECH 2001 CARNEGIE AVE. SANTA ANA, CA 92705 (949) 417-5207
INCORPORATED

6" THROAT WITH 4" IPS OUTLET

DWG NO. 277-02 REV J

SCALE .375 REF. - SHEET 1 OF 2

4

3

2

1

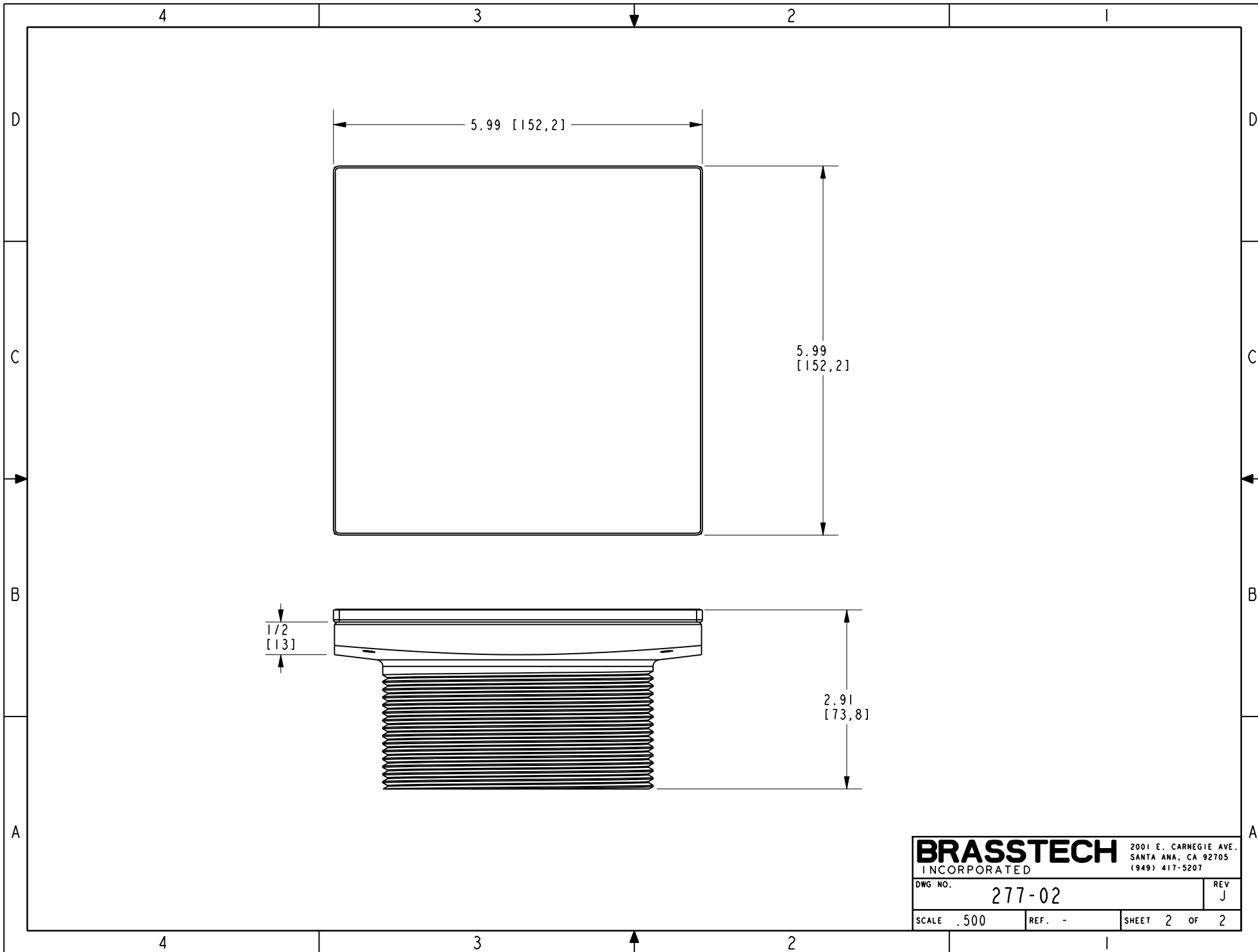

BRASSTECH		2001 E. CARNEGIE AVE.
INCORPORATED		SANTA ANA, CA 92705
		(949) 417-5207
DWG NO.	277-02	REV J
SCALE .500	REF. -	SHEET 2 OF 2