

NOTES:

1. TO INSPECT ASSEMBLY, FOLLOW FIRST ARTICLE AND IN PROCESS INSPECTION SHEET.

**BILL OF MATERIAL (CURRENT LEVEL)**

ITEM	PT/ASSY	DESCRIPTION	TYPE	QTY.
1	3-236	R/T SPOUT ASM	ASSEMBLY	1
2	3-188C	HANDLE ASM COLD	ASSEMBLY	1
3	3-188H	HANDLE ASM - HOT	ASSEMBLY	1

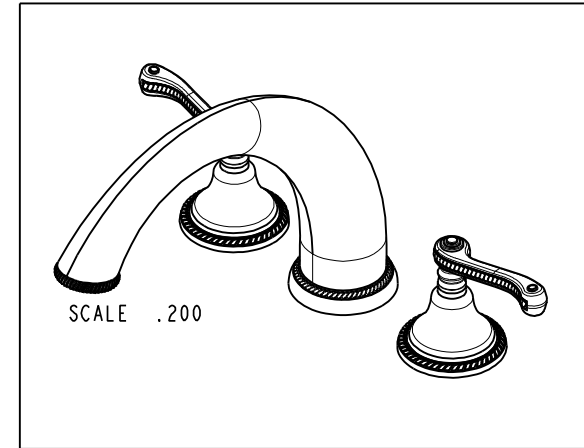
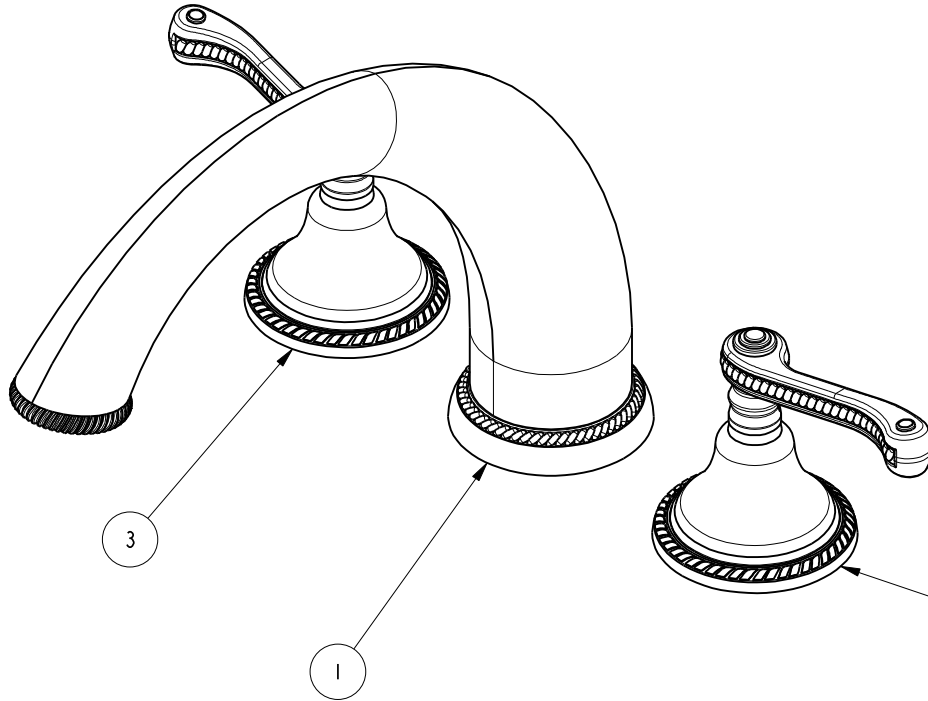

ZONE	REV	DESCRIPTION	DATE	APPROVED
-	B	EN-4300w	02/02/21	R.S.
-	A	EN-2032	01/07/14	-
-	-	RELEASED	-	-

COPYRIGHT 2005 BRASSTECH, INC. THESE DRAWINGS AND THE DESIGNS DEPICTED HEREIN ARE THE PROPRIETARY PROPERTY OF BRASSTECH. ANY USE OR REPRODUCTION IS SUBJECT TO THE EXPRESS APPROVAL OF BRASSTECH. UNAUTHORIZED USE IS STRICTLY PROHIBITED. ALL RIGHTS RESERVED.

TESTING	-	-	-
ASSEMBLY	-	-	-
PLATING	-	-	-
POLISHING	-	NEXT ASSY	USED ON
MACHINING	-	APPLICATION	
TOOLING FIXTURE #	REMOVE ALL BURRS AND SHARP EDGES		

UNITS ARE: INCHES [MM]		
TOLERANCES ARE:		
FRACTIONS	DECIMALS	ANGLES
±1/16"	.X ±.1 [2,5]	±°
	.XX ±.06 [1,5]	
(X.XXX) DENOTES CRITICAL DIMS.		
ALL THREADS ARE CRITICAL		
DRAWN	JINSON	02/02/21
CHECKED	R.S.	02/02/21
APPROVED	R.S.	02/02/21

**BRASSTECH** 2001 CARNEGIE AVE.  
INCORPORATED SANTA ANA, CA 92705  
(949) 417-5207

**ROMAN TUB - TRIM KIT**

DWG NO. **3-1026** REV **B**

SCALE .375 REF. - SHEET 1 OF 3

