

2.88 [73]
AMOUNT OF STEM REQ.
FROM FINISHED WALL

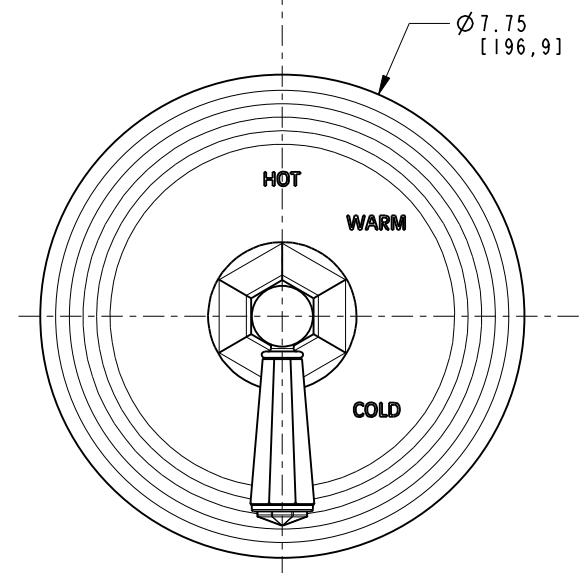
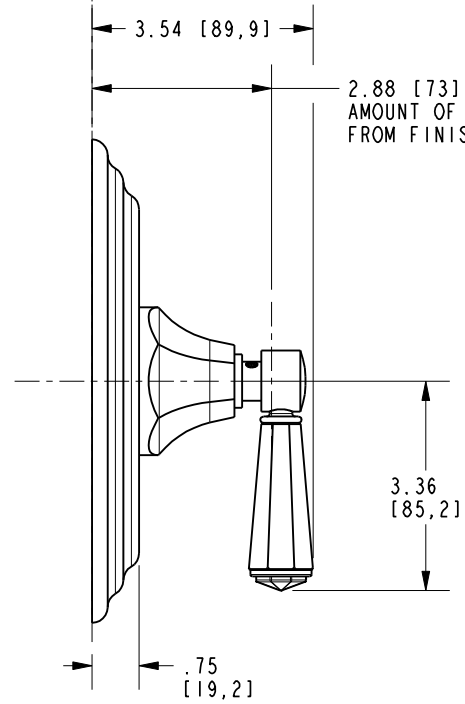

BRASSTECH		2001 E. CARNEGIE AVE. SANTA ANA, CA 92705 (949) 417-5207	
DWG NO.	3-1234BP	REV	D
SCALE	.325	REF.	-
		SHEET	2 OF 2