

4

3

2

1

D

D

C

C

B

B

A

A

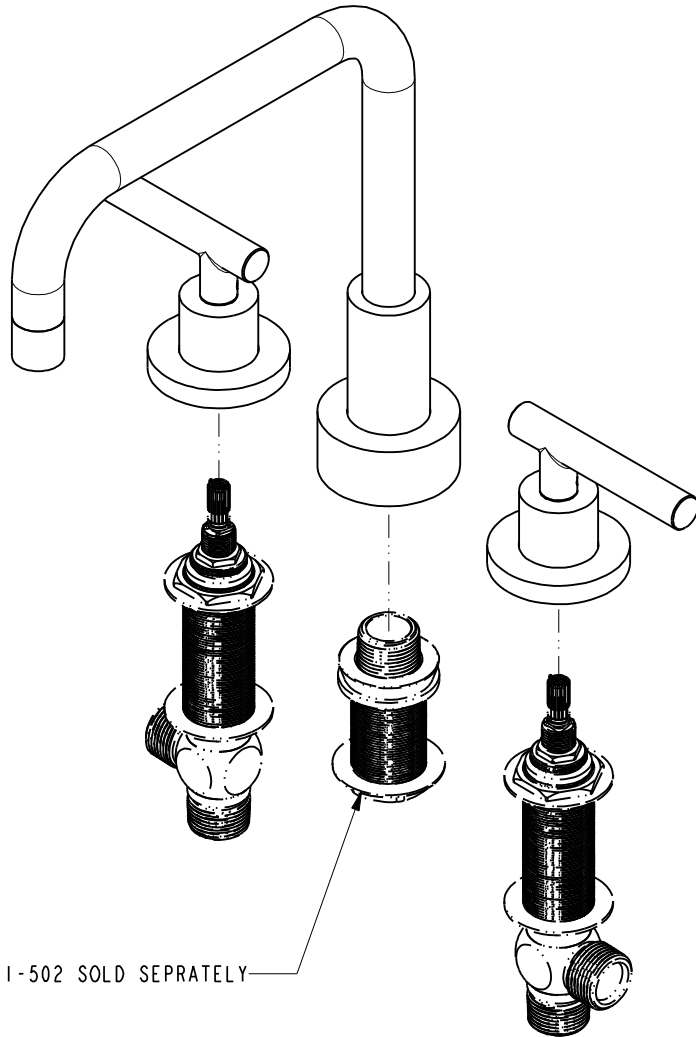

PART # 1-502 SOLD SEPRATELY

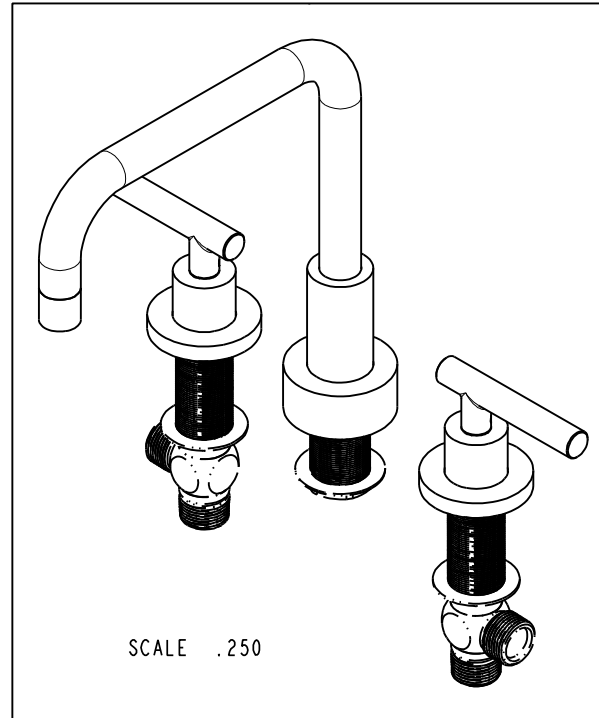

SCALE .250

BRASSTECH

2001 CARNEGIE AVE.
SANTA ANA, CA 92705
(949) 417-5207

INCORPORATED

DWG NO.

3-1406L

REV

C

SCALE .313

REF. -

SHEET 2 OF 3

4

3

2

1

