

NOTES:

1. TO INSPECT ASSEMBLY, FOLLOW FIRST ARTICLE AND IN PROCESS INSPECTION SHEET.
2. SEAL NUT 10259 IN A PLASTIC BAG AND TAPE TO THE BACK OF THE TRIM PLATE.

**BILL OF MATERIAL (CURRENT LEVEL)**

ITEM	PT/ASSY	DESCRIPTION	TYPE	QTY.
1	2-661	SHOWER PLATE ASM	ASSEMBLY	1
2	2-503	SHOWER FLANGE ASM	ASSEMBLY	1
3	50822	8" SHWR ARM (201)	PART	1
4	2142	TRAD. SHOWER HEAD - SINGLE JET	ASSEMBLY	1
5	3-374	CROSS HANDLE AND ESC. ASM	ASSEMBLY	1
6	10259	HEX NUT 9/16 X 20 MADE	PART	1

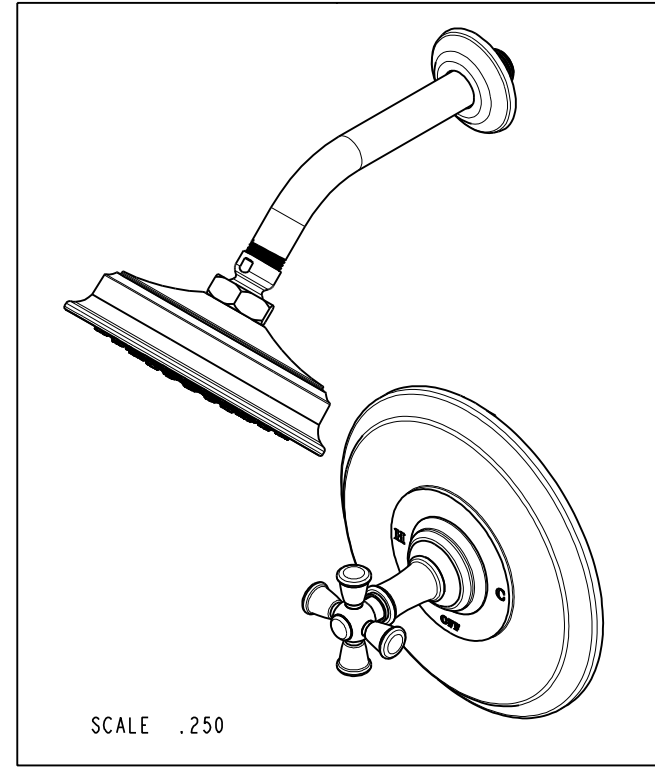
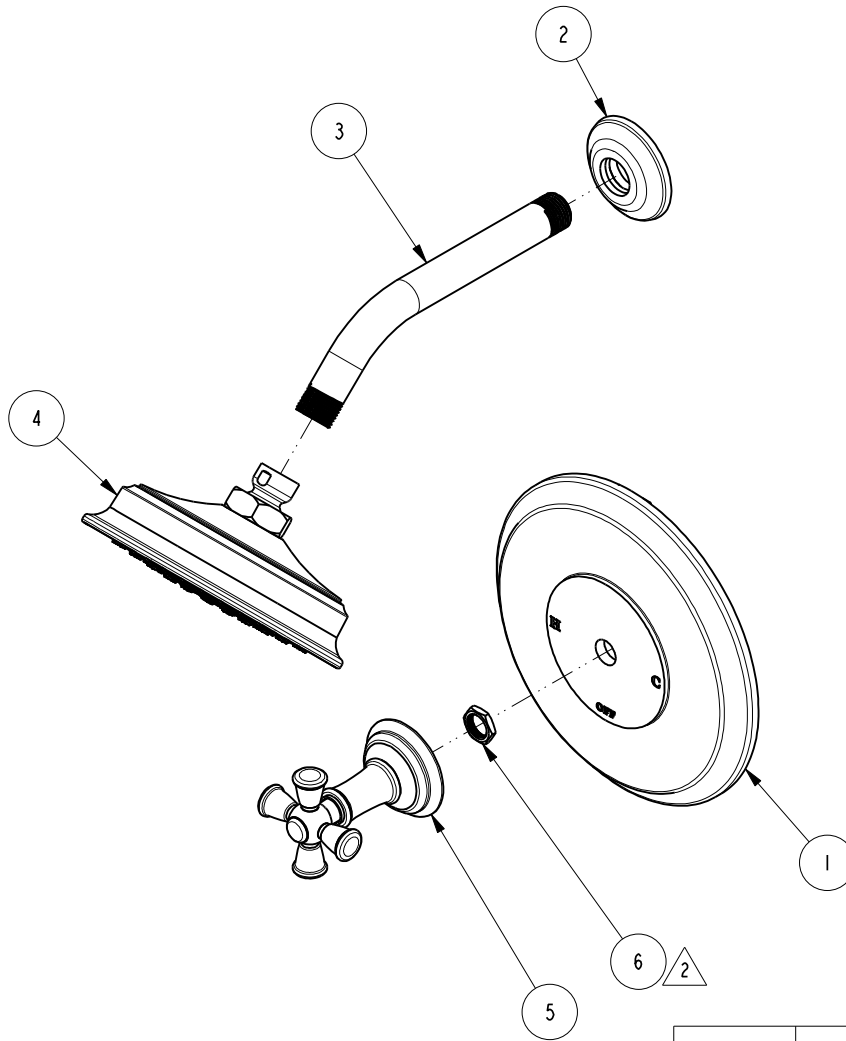

ZONE	REV	DESCRIPTION	DATE	APPROVED
-	C	EN-4441	04/18/22	N.S.
-	B	EN-4300e	04/28/21	R.S.
-	A	EN-1183	03/23/09	-
-	-	EN-1266	05/05/10	-

COPYRIGHT 2005 BRASSTECH, INC. THESE DRAWINGS AND THE DESIGNS DEPICTED HEREIN ARE THE PROPRIETARY PROPERTY OF BRASSTECH. ANY USE OR REPRODUCTION IS SUBJECT TO THE EXPRESS APPROVAL OF BRASSTECH. UNAUTHORIZED USE IS STRICTLY PROHIBITED. ALL RIGHTS RESERVED.

TESTING	-	-	-
ASSEMBLY	-	-	-
PLATING	-	-	-
POLISHING	-	NEXT ASSY	USED ON
MACHINING	-	APPLICATION	
TOOLING FIXTURE #	REMOVE ALL BURRS AND SHARP EDGES		

UNITS ARE: INCHES [MM]  
 TOLERANCES ARE:  
 FRACTIONS DECIMALS ANGLES  
 $\pm 1/16"$  .X  $\pm .1$  [2,5]  $\pm ^\circ$   
 .XX  $\pm .06$  [1,5]  
 (X.XXX) DENOTES CRITICAL DIMS.  
 ALL THREADS ARE CRITICAL  
 DRAWN J.T. 04/18/22  
 CHECKED N.S. 04/18/22  
 APPROVED N.S. 04/18/22

**BRASSTECH** 2001 CARNEGIE AVE.  
 INCORPORATED SANTA ANA, CA 92705  
 (949) 417-5207

**B/P SHOWER TRIM KIT**

DWG NO. **3-2404BP** REV **C**

SCALE .250 REF. - SHEET 1 OF 2

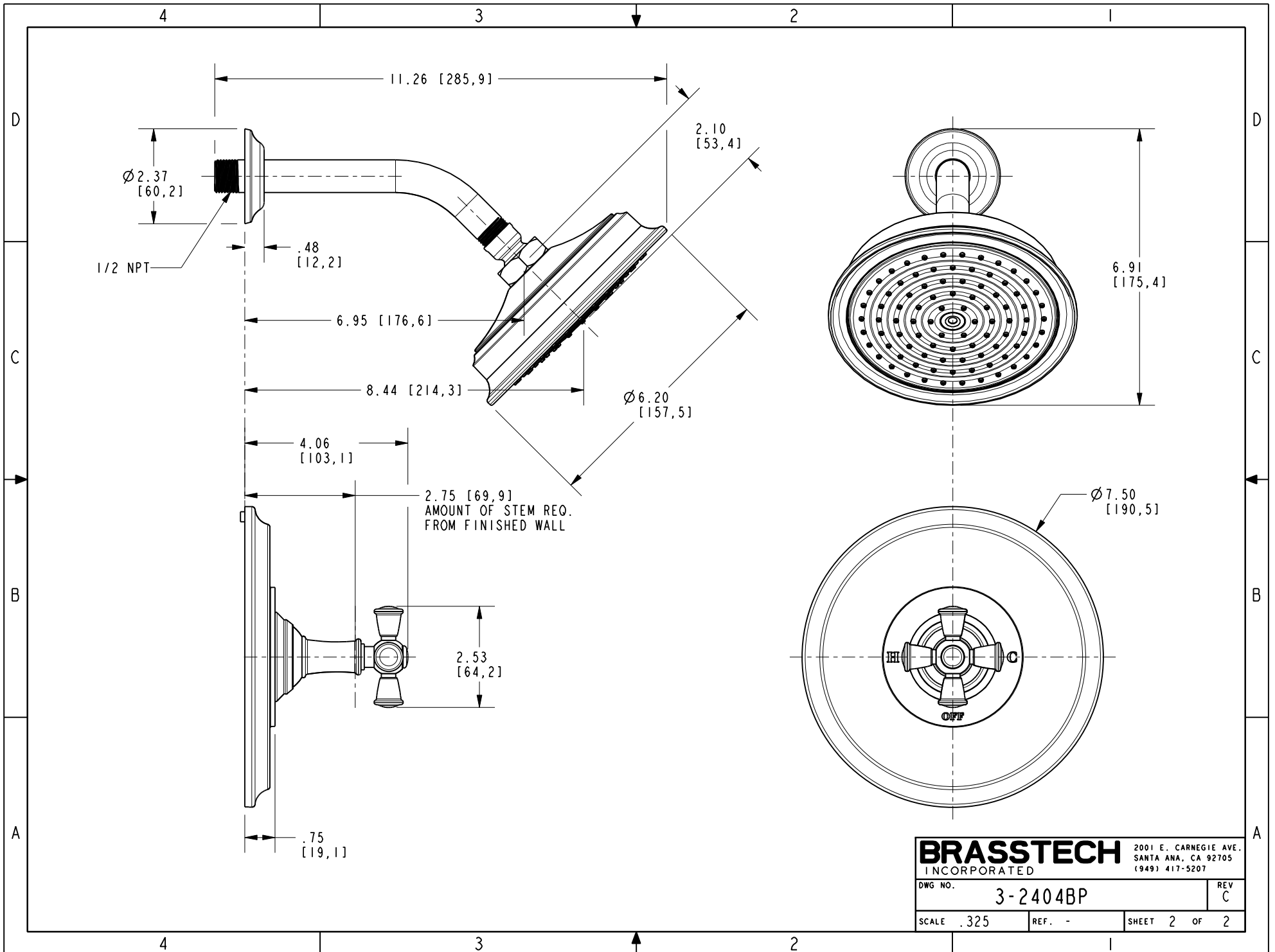

<b>BRASSTECH</b>		2001 E. CARNEGIE AVE. SANTA ANA, CA 92705 (949) 417-5207	
DWG NO.	3-2404BP		REV C
SCALE	.325	REF.	-
SHEET 2		OF 2	