

NOTES:

1. TO INSPECT ASSEMBLY, FOLLOW FIRST ARTICLE AND IN PROCESS INSPECTION SHEET.

BILL OF MATERIAL (CURRENT LEVEL)

ITEM	PT/ASSY	DESCRIPTION	TYPE	QTY.
1	3-379	LEVER HANDLE ASSEMBLY	ASSEMBLY	2
2	3-669	SPOUT ASM W/ ESCUTCHEON TUB	ASSEMBLY	1

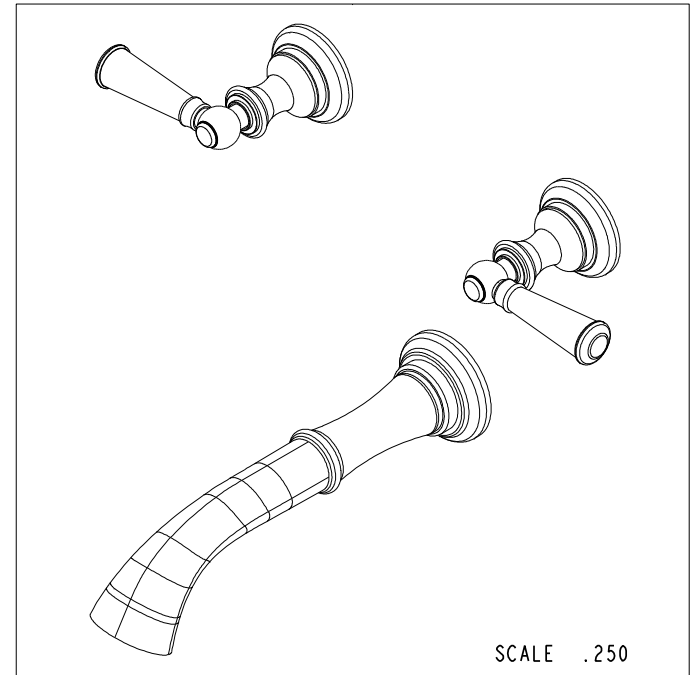
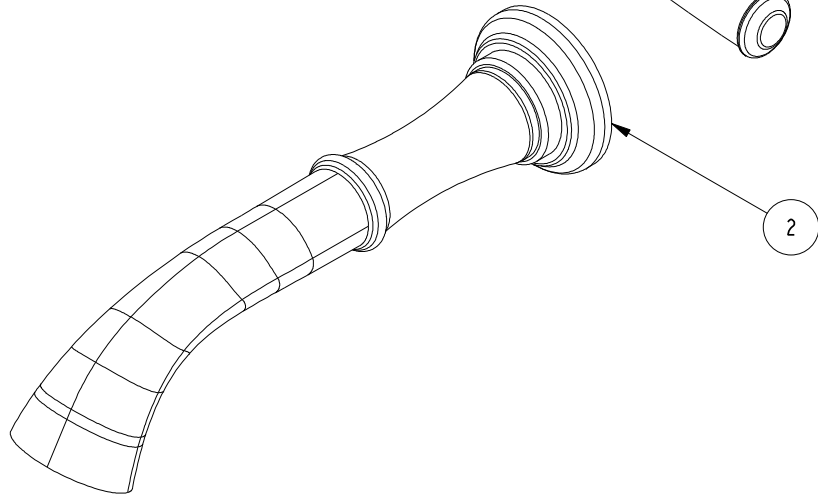
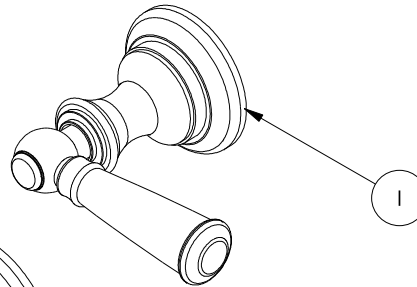
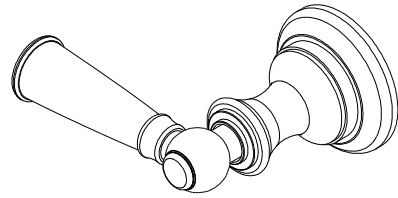

ZONE	REV	DESCRIPTION	DATE	APPROVED
-	C	EN-3961-2	05/28/20	R.S.
-	B	EN-3892	06/19/19	J.M.
-	A	EN-3072	12/20/17	J.M.
-	-	EN-1266	05/14/10	-

COPYRIGHT 2005 BRASSTECH, INC. THESE DRAWINGS AND THE DESIGNS DEPICTED HEREIN ARE THE PROPRIETARY PROPERTY OF BRASSTECH. ANY USE OR REPRODUCTION IS SUBJECT TO THE EXPRESS APPROVAL OF BRASSTECH. UNAUTHORIZED USE IS STRICTLY PROHIBITED. ALL RIGHTS RESERVED.

TESTING	-	-	-
ASSEMBLY	-	-	-
PLATING	-	-	-
POLISHING	-	NEXT ASSY	USED ON
MACHINING	-	APPLICATION	
TOOLING FIXTURE #	REMOVE ALL BURRS AND SHARP EDGES		

UNITS ARE: INCHES [MM]
TOLERANCES ARE:
FRACTIONS DECIMALS ANGLES
±1/16" .X ±.1 [2.5] ±1°
.XX ±.06 [1.5]

(X.XXX) DENOTES CRITICAL DIMS.
ALL THREADS ARE CRITICAL

DRAWN	JIMSON	05/28/20
CHECKED	R.S.	05/28/20
APPROVED	R.S.	05/28/20

BRASSTECH
INCORPORATED

2001 CARNEGIE AVE.
SANTA ANA, CA 92705
(949) 417-5207

WALL MOUNTED TUB TRIM KIT

DWG NO.	3-2455	REV	C
SCALE	.375	REF.	-
SHEET	1	OF	3

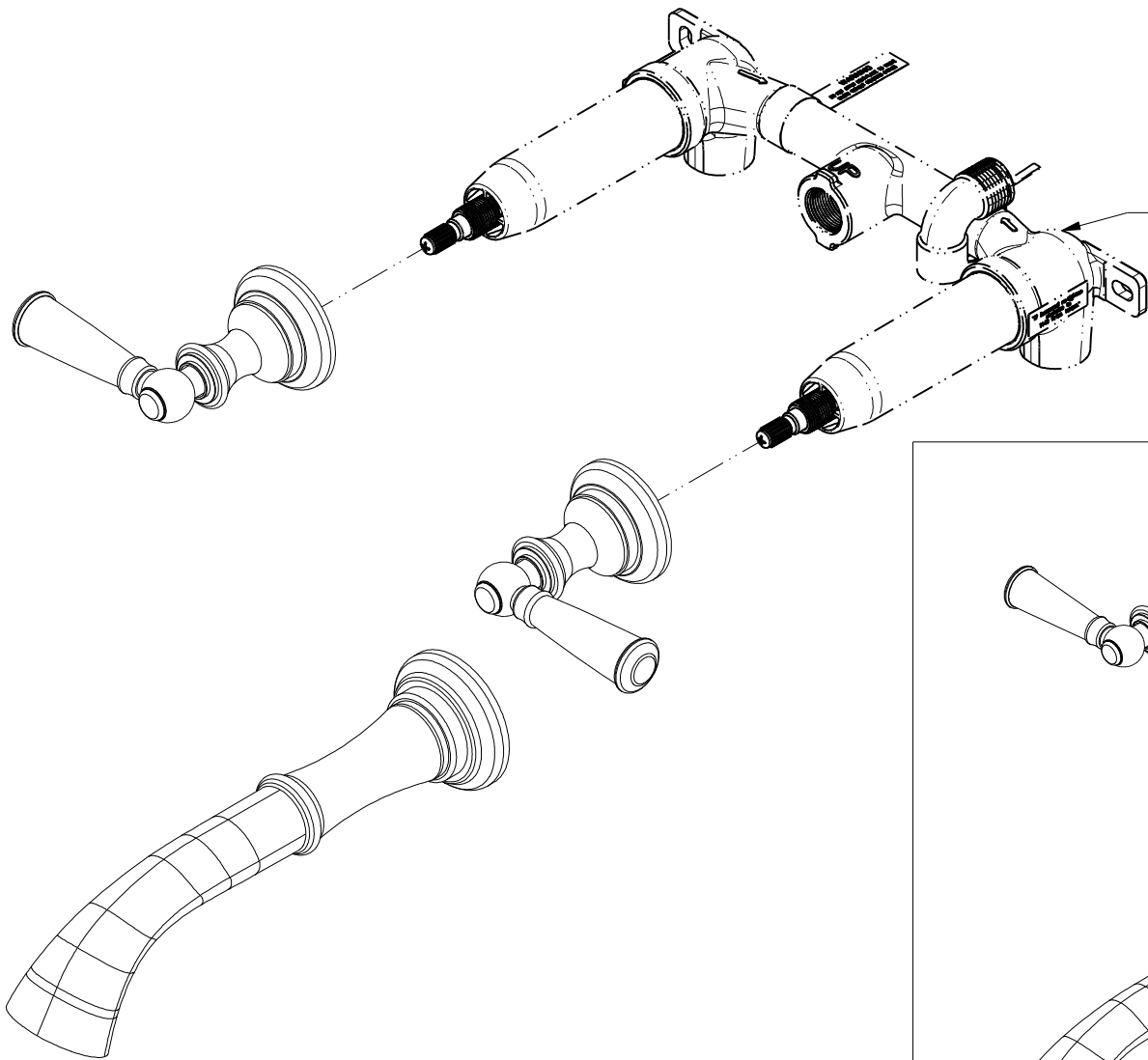

PN: 1-500U
SOLD SEPARATELY

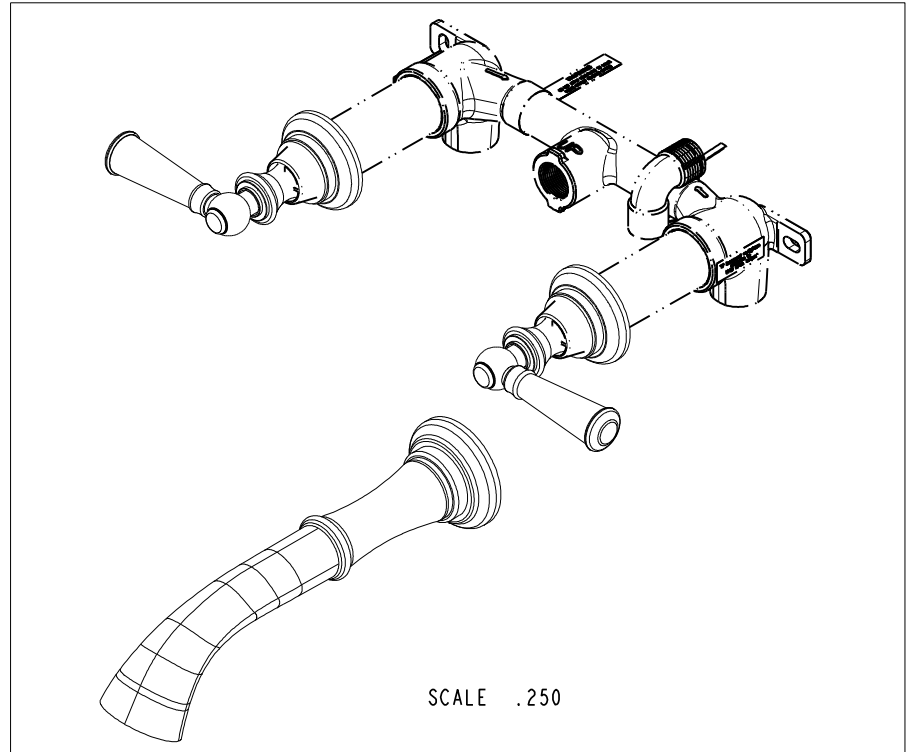

SCALE .250

BRASSTECH		2001 CARNEGIE AVE. SANTA ANA, CA 92705 (949) 417-5207	
INCORPORATED			
DWG NO.	3-2455	REV	C
SCALE	.325	REF.	-
		SHEET	2 OF 3

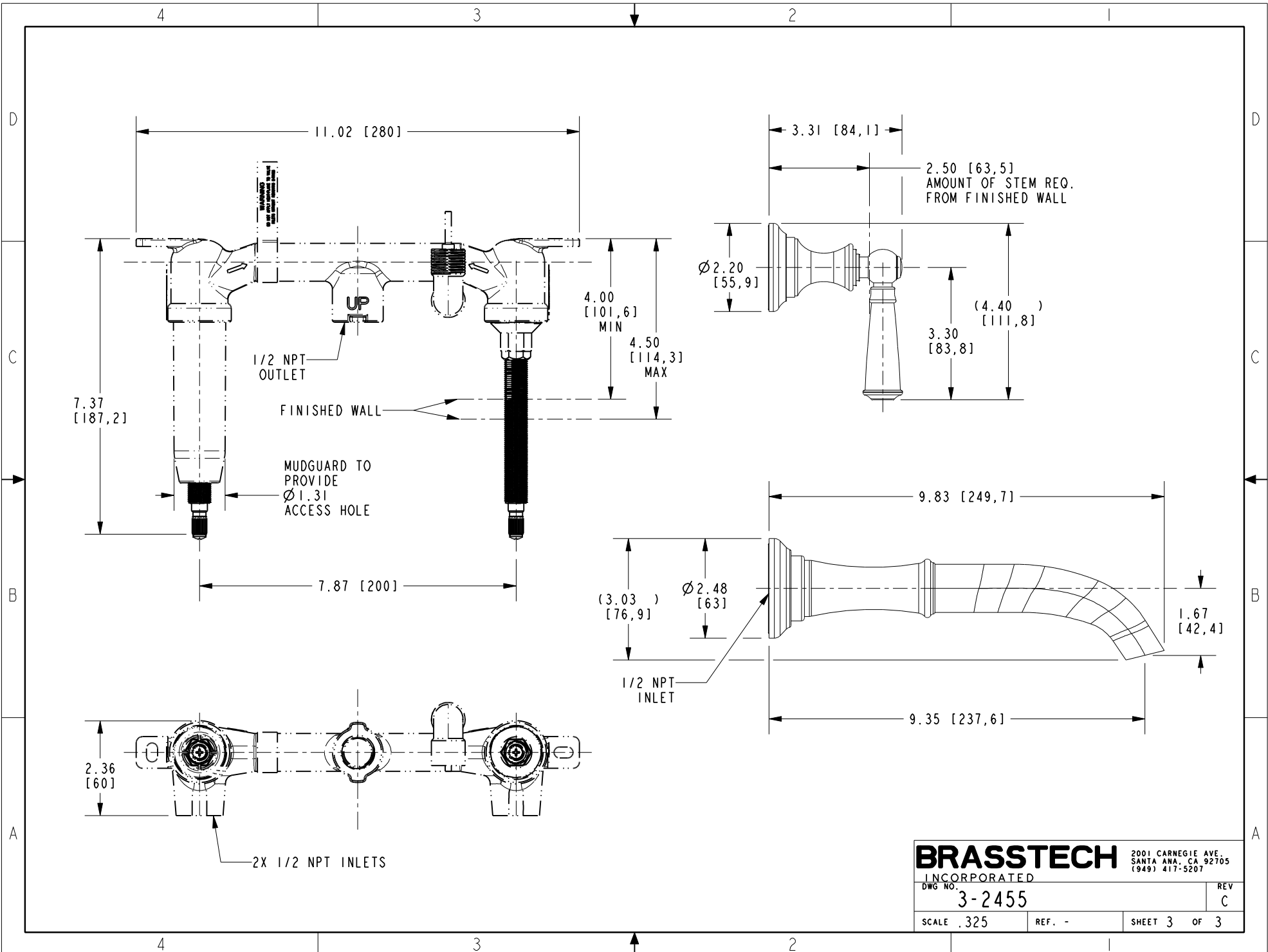

BRASSTECH 2001 CARNEGIE AVE.
 INCORPORATED SANTA ANA, CA 92705
 (949) 417-5207

DWG NO. 3-2455	REV C
SCALE .325	REF. -
SHEET 3	OF 3