

NOTES:

1. TO INSPECT ASSEMBLY, FOLLOW FIRST ARTICLE AND IN PROCESS INSPECTION SHEET.

BILL OF MATERIAL (CURRENT LEVEL)

ITEM	PT/ASSY	DESCRIPTION	TYPE	QTY.
1	20-502	BP SHOWER PLATE ASM	ASSEMBLY	1
2	20-107	HANDLE ASM	ASSEMBLY	1
3	206-1	SHOWER - ESCUTCHEON ASM	ASSEMBLY	1
4	2-811	SHOWER ARM BRAZE ASM	ASSEMBLY	1
5	2141	CONTEMP. SHOWER HEAD - SINGLE JET	ASSEMBLY	1

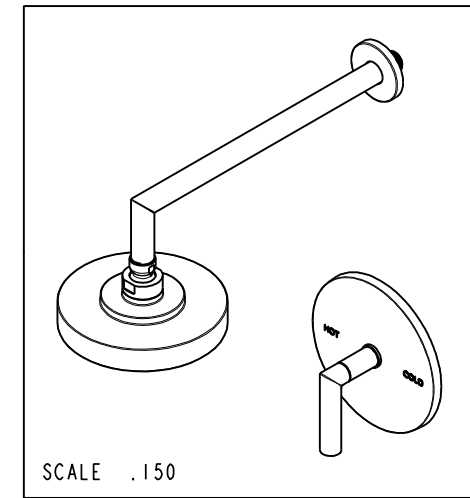
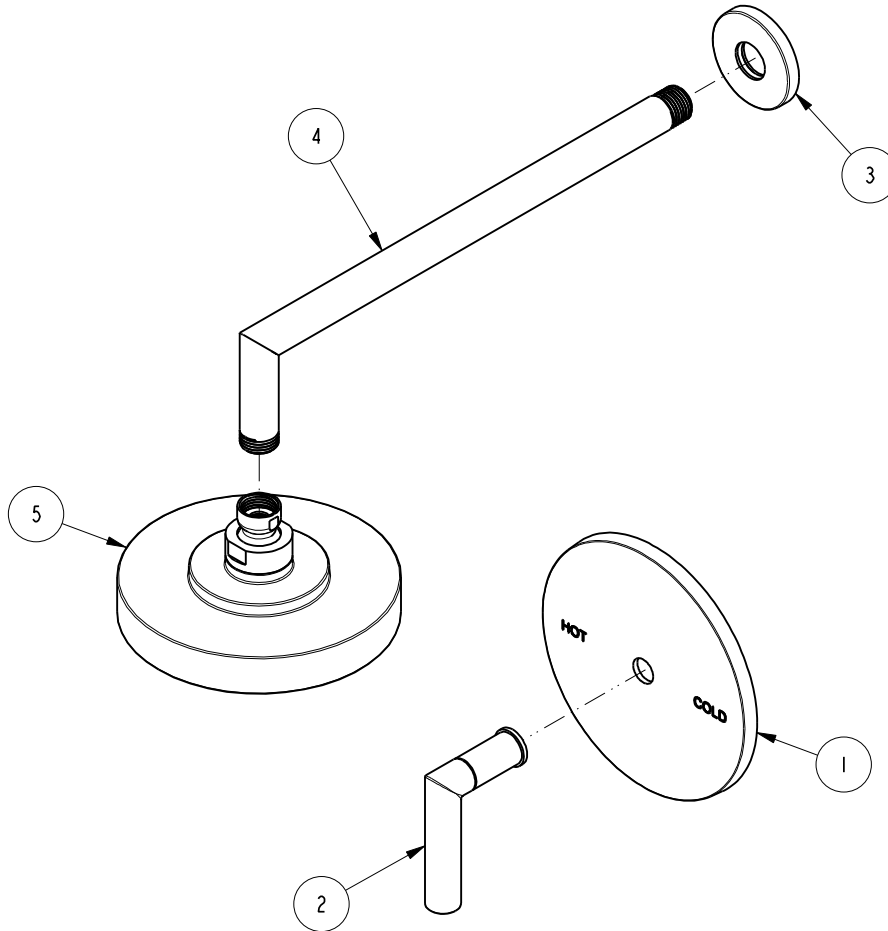

ZONE	REV	DESCRIPTION	DATE	APPROVED
-	C	EN-4300e	04/28/21	R.S.
-	B	EN-4154	06/05/20	N.S.
-	A	EN-3254	02/02/17	AN
-	-	EN-3032d	07/13/16	AN

COPYRIGHT 2005 BRASSTECH, INC. THESE DRAWINGS AND THE DESIGNS DEPICTED HEREIN ARE THE PROPRIETARY PROPERTY OF BRASSTECH. ANY USE OR REPRODUCTION IS SUBJECT TO THE EXPRESS APPROVAL OF BRASSTECH. UNAUTHORIZED USE IS STRICTLY PROHIBITED. ALL RIGHTS RESERVED.

TESTING	-	-	-
ASSEMBLY	-	-	-
PLATING	-	-	-
POLISHING	-	NEXT ASSY	USED ON
MACHINING	-	APPLICATION	
TOOLING FIXTURE #	REMOVE ALL BURRS AND SHARP EDGES		

UNITS ARE: INCHES [MM]	
TOLERANCES ARE:	
FRACTIONS	DECIMALS
±1/16"	.X ±.1 [2,5]
	.XX ±.06 [1,5]
ANGLES ±1°	
(X.XXX) DENOTES CRITICAL DIMS.	
ALL THREADS ARE CRITICAL	
DRAWN	JINSON 04/28/21
CHECKED	R.S. 04/28/21
APPROVED	R.S. 04/28/21

BRASSTECH 2001 CARNEGIE AVE. SANTA ANA, CA 92705 (949) 417-5207
INCORPORATED

BP SHOWER TRIM SET

DWG NO. **3-3124BP** REV **C**

SCALE .250 REF. - SHEET 1 OF 2

