

NOTES:

1. TO INSPECT ASSEMBLY, FOLLOW FIRST ARTICLE AND IN PROCESS INSPECTION SHEET.

2. APPLY LOCTITE 680.

BILL OF MATERIAL (CURRENT LEVEL)

ITEM	PT/ASSY	DESCRIPTION	TYPE	QTY.
1	40842	ROSETTE	PART	1
2	40380	SINGLE ROBE HOOK ARM	PART	1
3	40843	HOOK FINAL	PART	1
4	02XXG	MOUNTING BRACKET	PART	1
5	1-206	HARDWARE PACK	ASSEMBLY	1
6	92031	SCRW, M6 X 1 X 6 SKT HD CUP PT SS	PART	1
7	10615	HEX KEY, 3MM ALLOY STEEL	PART	1

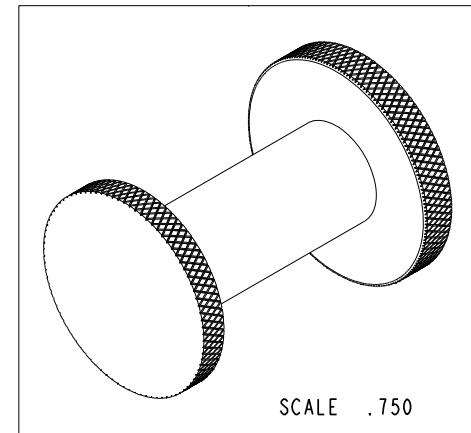
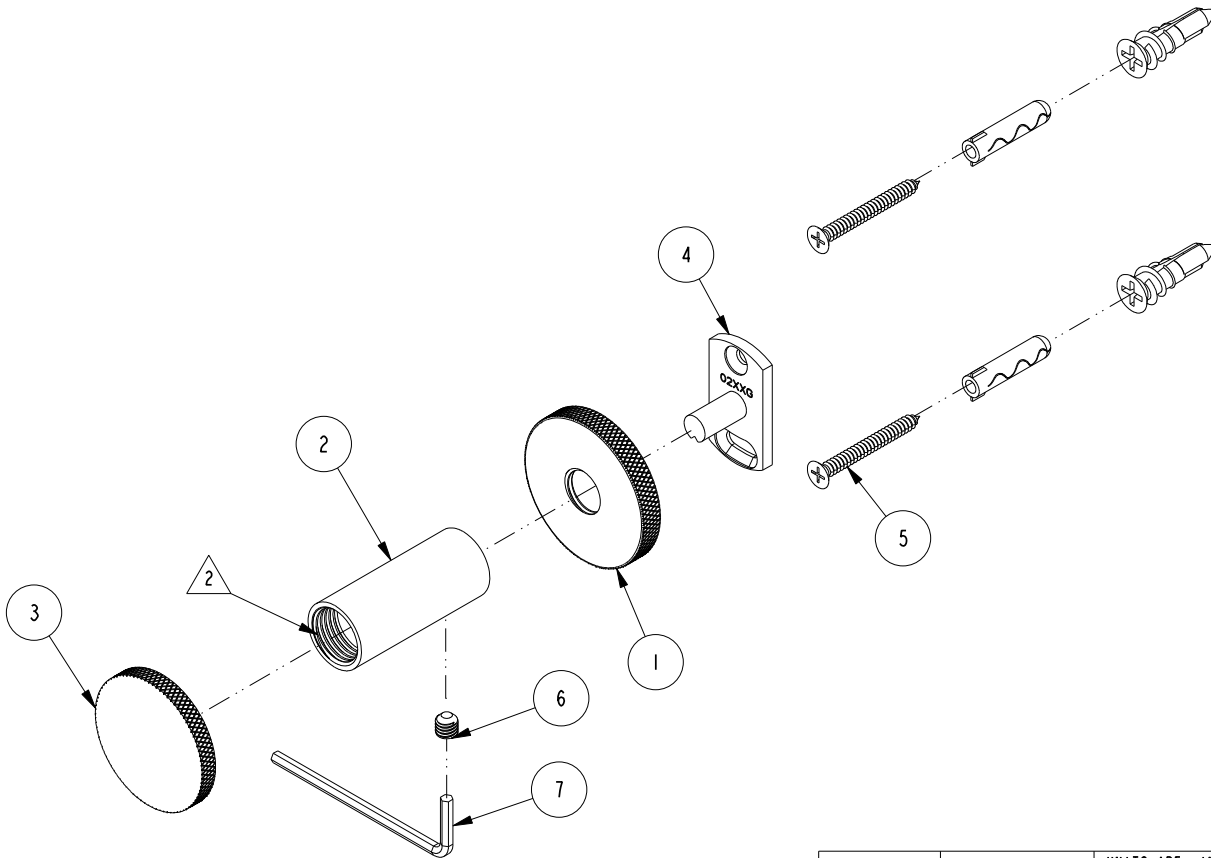

TESTING	-	-	-
ASSEMBLY	-	-	-
PLATING	-	-	-
POLISHING	-	NEXT ASSY	USED ON
MACHINING	-	APPLICATION	
TOOLING FIXTURE #	REMOVE ALL BURRS AND SHARP EDGES		

UNITS ARE: INCHES [MM]		
TOLERANCES ARE:		
FRACTIONS	DECIMALS	ANGLES
±1/16"	.X ±.1 [2.5]	±1°
	.XX ±.06 [1.5]	
(X.XXX) DENOTES CRITICAL DIMS.		
ALL THREADS ARE CRITICAL		
DRAWN	JINSON	05/15/20
CHECKED	J.M.	05/15/20
APPROVED	J.M.	05/15/20

BRASSTECH 2001 CARNEGIE AVE.
INCORPORATED SANTA ANA, CA 92705
(949) 417-5207

SINGLE ROBE HOOK

DWG NO. **3290-1650** REV **A**

SCALE **.500** REF. **-** SHEET **1** OF **2**

COPYRIGHT 2005 BRASSTECH, INC. THESE DRAWINGS AND THE DESIGNS DEPICTED HEREIN ARE THE PROPRIETARY PROPERTY OF BRASSTECH. ANY USE OR REPRODUCTION IS SUBJECT TO THE EXPRESS APPROVAL OF BRASSTECH. UNAUTHORIZED USE IS STRICTLY PROHIBITED. ALL RIGHTS RESERVED.

-	A	EN-4300T	06/29/22	R. S.
-	-	EN-4115	05/15/20	J. M.
ZONE	REV	DESCRIPTION	DATE	APPROVED

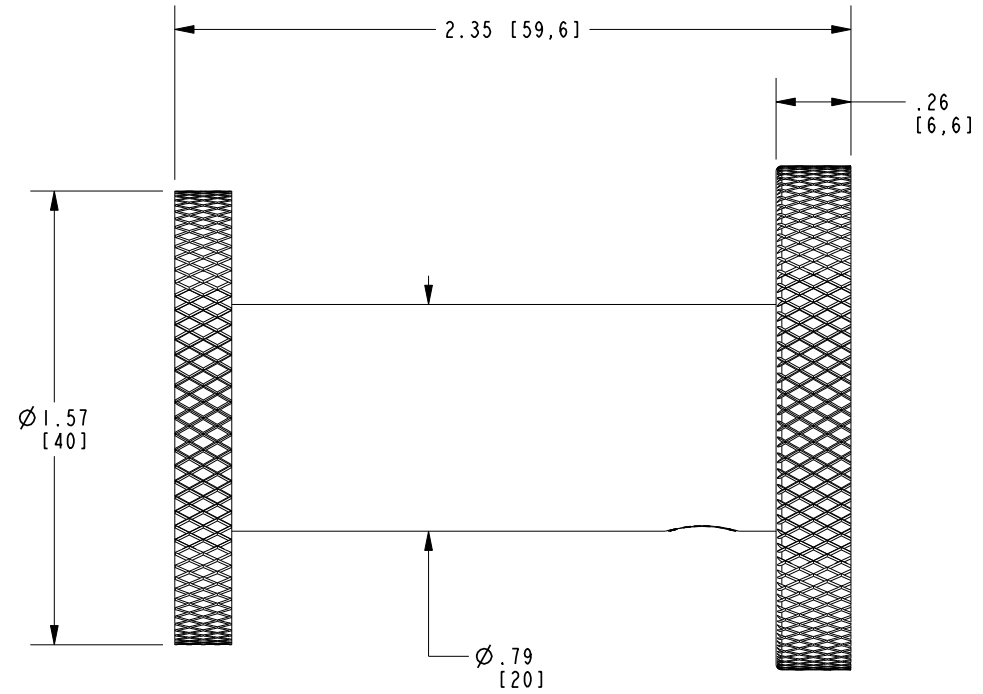
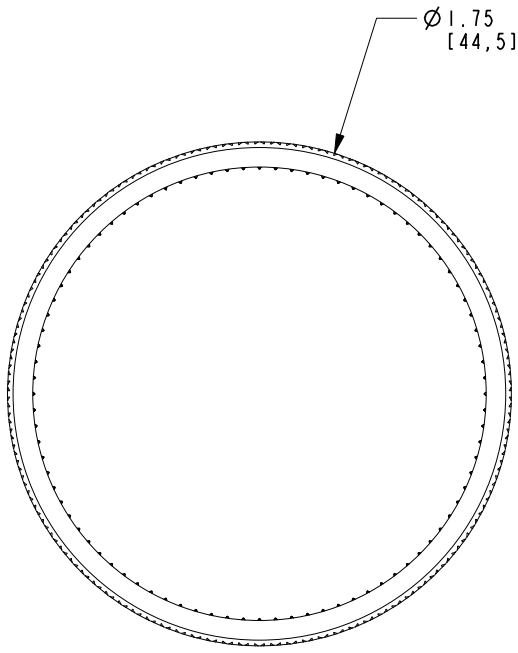

BRASSTECH		2001 E. CARNEGIE AVE. SANTA ANA, CA 92705 (949) 417-5207	
DWG NO.	3290-1650	REV	A
SCALE	1.500	REF.	-
		SHEET	2 OF 2