

NOTES:

1. TO INSPECT ASSEMBLY, FOLLOW FIRST ARTICLE AND IN PROCESS INSPECTION SHEET.

2 APPLY PERMANENT THREAD LOCKER (LOCTITE 680)

BILL OF MATERIAL (CURRENT LEVEL)

ITEM	PT/ASSY	DESCRIPTION	TYPE	QTY.
1	40376	ROSETTE	PART	1
2	40380	SINGLE ROBE HOOK ARM	PART	1
3	40785	HOOK FINAL	PART	1
4	02XXG	MOUNTING BRACKET	PART	1
5	1-206	HARDWARE PACK	ASSEMBLY	1
6	92031	SCRW, M6 X 1 X 6 SKT HD CUP PT SS	PART	1
7	10615	HEX KEY, 3MM ALLOY STEEL	PART	1

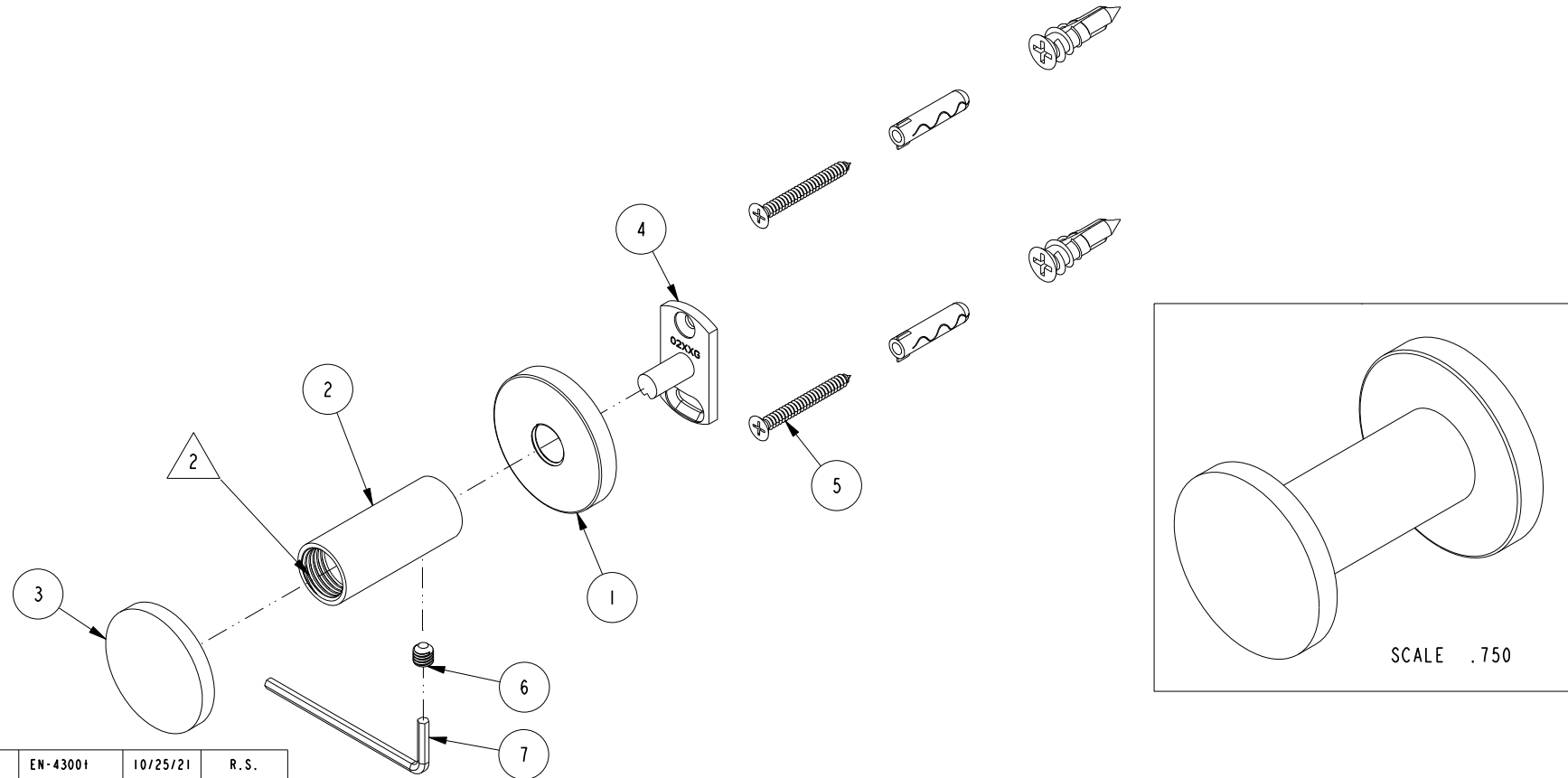

-	F	EN-43001	10/25/21	R.S.
-	E	EN-4238b	10/27/20	J.M.
-	D	EN-4150	03/31/20	R.S.
-	C	EN-4129	03/12/20	R.S.
-	B	EN-4032	12/05/19	R.S.
-	A	EN-1893	11/14/11	R.S.
-	-	EN-0995-1	11/10/10	J.M.
ZONE	REV	DESCRIPTION	DATE	APPROVED

COPYRIGHT 2005 BRASSTECH, INC. THESE DRAWINGS AND THE DESIGNS DEPICTED HEREIN ARE THE PROPRIETARY PROPERTY OF BRASSTECH. ANY USE OR REPRODUCTION IS SUBJECT TO THE EXPRESS APPROVAL OF BRASSTECH. UNAUTHORIZED USE IS STRICTLY PROHIBITED. ALL RIGHTS RESERVED.

TESTING	-	-	-
ASSEMBLY	-	-	-
PLATING	-	-	-
POLISHING	-	NEXT ASSY	USED ON
MACHINING	-	APPLICATION	
TOOLING FIXTURE #	REMOVE ALL BURRS AND SHARP EDGES		

UNITS ARE: INCHES [MM]		
TOLERANCES ARE:		
FRACTIONS	DECIMALS	ANGLES
±1/16"	.X ±.1 [2.5]	±1°
	.XX ±.06 [1.5]	
(X.XXX) DENOTES CRITICAL DIMS.		
ALL THREADS ARE CRITICAL		
DRAWN	JINSON	10/25/21
CHECKED	R.S.	10/25/21
APPROVED	R.S.	10/25/21

BRASSTECH 2001 CARNEGIE AVE. SANTA ANA, CA 92705 (949) 417-5207
INCORPORATED

SINGLE HOOK ASSEMBLY

DWG NO. **36-12** REV **F**

SCALE .500 REF. - SHEET 1 OF 2

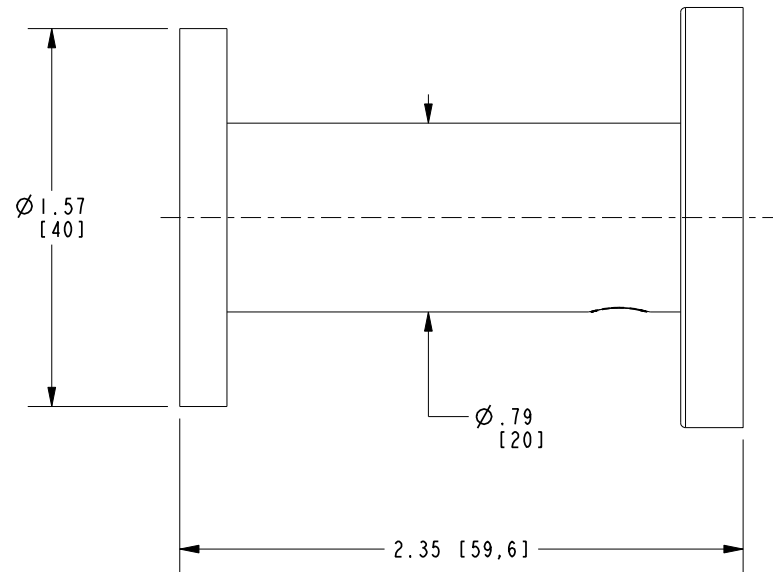
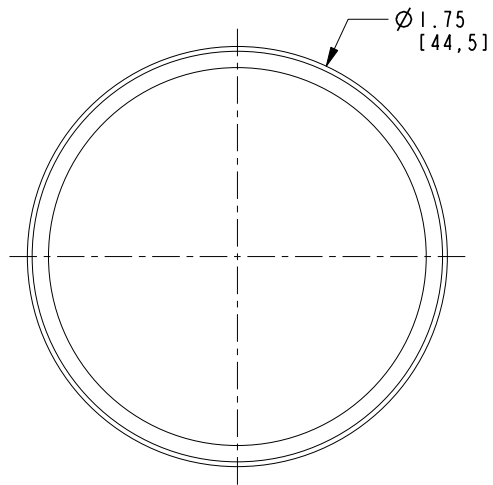

BRASSTECH		2001 E. CARNEGIE AVE. SANTA ANA, CA 92705 (949) 417-5207	
DWG NO.	36-12	REV	F
SCALE	1,250	REF.	-
SHEET		2	OF 2