

NOTES:

- (N1) 1. FIT / FORM / FUNCTION SHALL FOLLOW PS-E.008.
- (N2) $\triangle 2$ APPLY LIGHT FILM OF DOW III CRONING SILICON GREASE
- (N3) $\triangle 3$ APPLY PERMANENT THREAD LOCKER (LOCTITE 680)
- (N4) 4 PLACE ITEM# 1, 3 AND 9 IN SEPARATE BAG

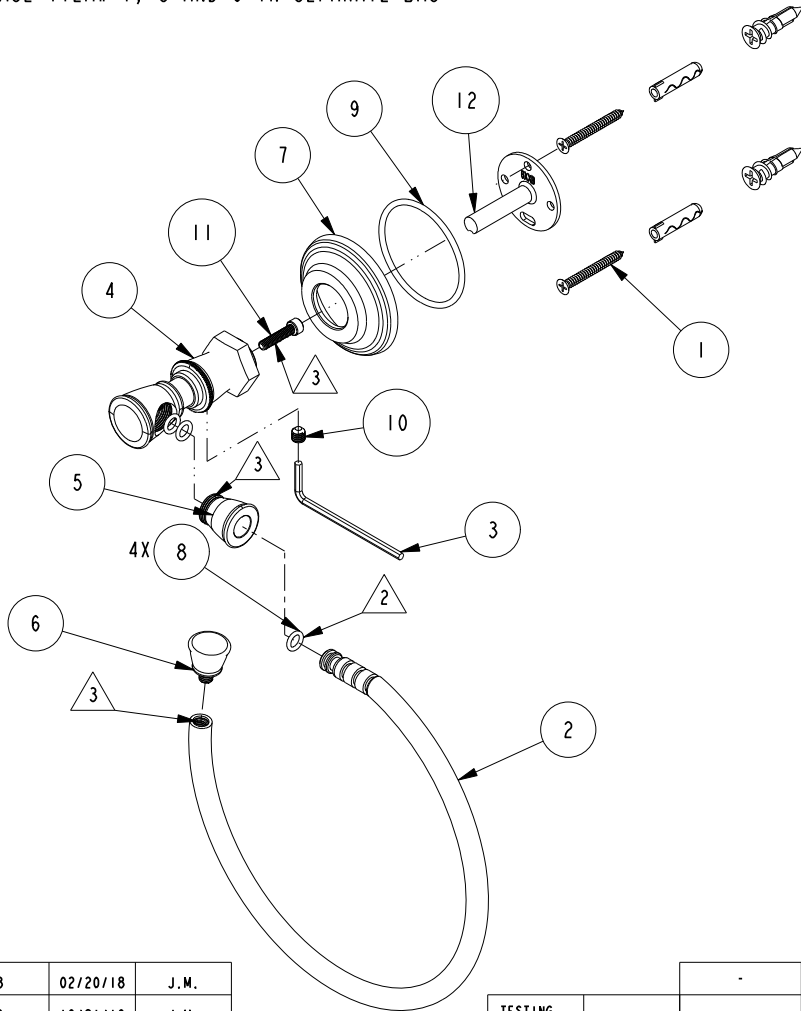

BILL OF MATERIAL (CURRENT LEVEL)

ITEM	PT/ASSY	DESCRIPTION	TYPE	QTY.
1	1-206	HARDWARE PACK	ASSEMBLY	1
2	7-731	TOWEL RING	ASSEMBLY	1
3	10615	HEX KEY, 3MM ALLOY STEEL	PART	1
4	40535	POST	PART	1
5	40536	FINIAL	PART	1
6	40538	RING CAP	PART	1
7	40553	ESCUTCHEON	PART	1
8	91049	O-RING, #2- 010, EPDM, 65-75 DURO, NSF 61	PART	4
9	91298	O-RING, #2-134	PART	1
10	92031	SCRW, M6 X 1 X 6 SKT HD CUP PT SS	PART	1
11	92528	SCRW, 8-32 X 3/4 SKT CAP HD SS	PART	1
12	6XXB	MOUNTING BRACKET	PART	1

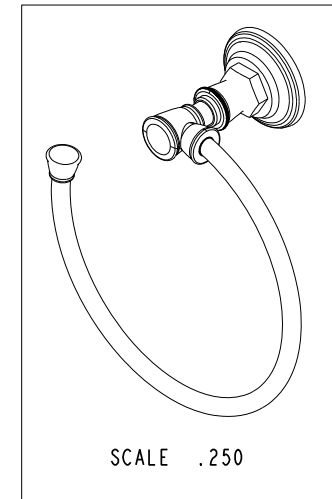

-	E	EN-3538	02/20/18	J.M.
-	D	EN-3169	10/21/16	J.M.
-	C	EN-3112	08/15/16	J.M.
-	B	EN-3089	06/30/16	J.M.
-	A	EN-2717	04/16/14	J.M.
-	-	EN-2086	09/01/13	-
ZONE	REV	DESCRIPTION	DATE	APPROVED

COPYRIGHT 2005 BRASSTECH, INC. THESE DRAWINGS AND THE DESIGNS DEPICTED HEREIN ARE THE PROPRIETARY PROPERTY OF BRASSTECH. ANY USE OR REPRODUCTION IS SUBJECT TO THE EXPRESS APPROVAL OF BRASSTECH. UNAUTHORIZED USE IS STRICTLY PROHIBITED. ALL RIGHTS RESERVED.

TESTING	-	-	-
ASSEMBLY	-	-	-
PLATING	-	-	-
POLISHING	-	NEXT ASSY	USED ON
MACHINING	-	APPLICATION	
TOOLING FIXTURE #	REMOVE ALL BURRS AND SHARP EDGES		

UNITS ARE: INCHES [MM]
TOLERANCES ARE:
FRACTIONS DECIMALS ANGLES
 $\pm 1/16"$.X $\pm .1$ [2.5] $\pm 1"$
.XX $\pm .06$ [1.5]
(X.XXX) DENOTES CRITICAL DIMS.
ALL THREADS ARE CRITICAL

BRASSTECH		<small>2001 CARNEGIE AVE. SANTA ANA, CA 92705 (949) 417-5207</small>	
INCORPORATED		TOWEL RING	
DWG NO.		REV	
40-10		E	
SCALE	REF.	SHEET	OF
.300	-	1	2

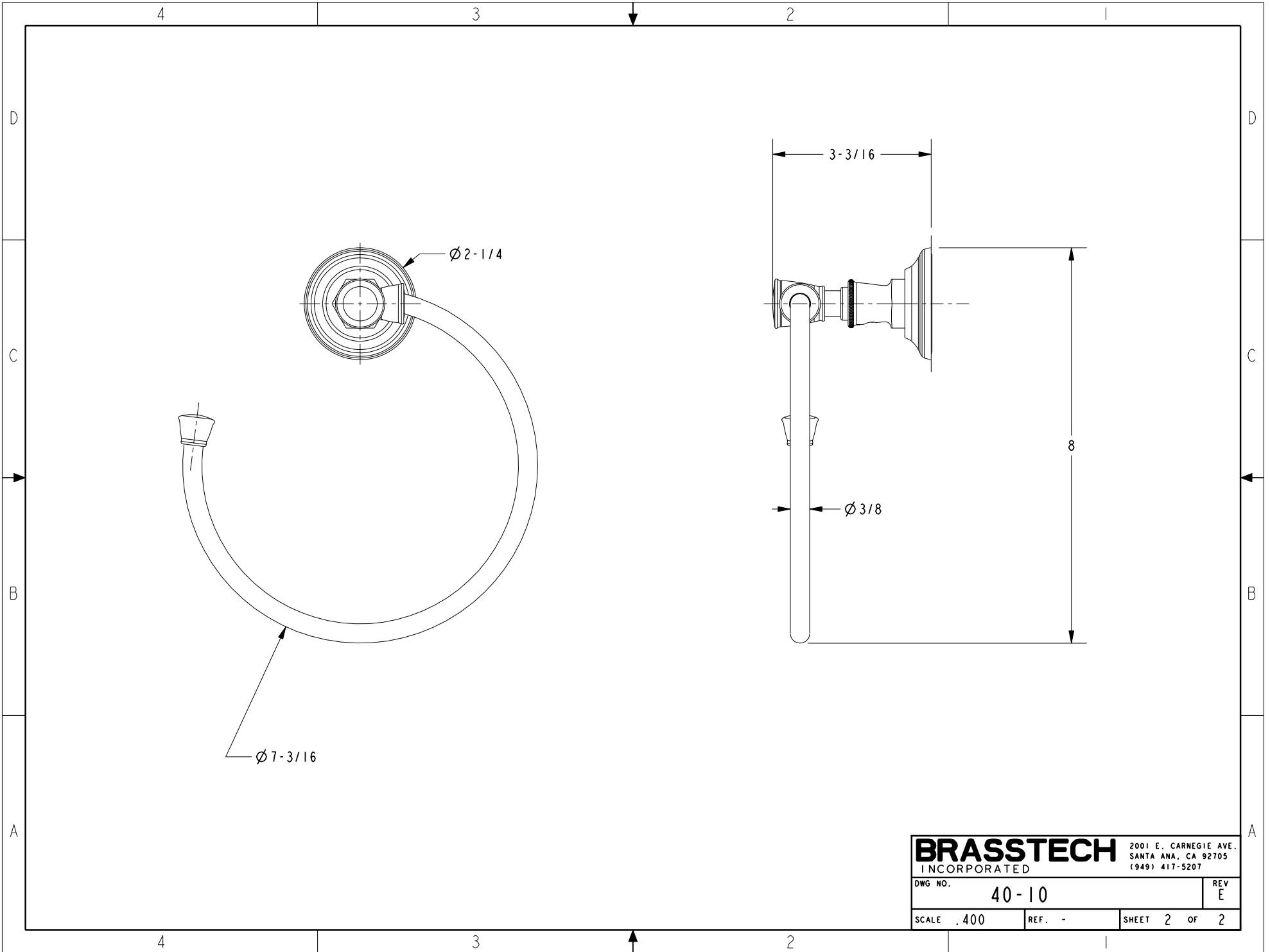

BRASSTECH		2001 E. CARNEGIE AVE.	
INCORPORATED		SANTA ANA, CA 92705	
		(949) 417-5207	
DWG NO.	40-10	REV	E
SCALE	.400	REF.	-
		SHEET	2 OF 2