

NOTES:

- (N1) 1. FIT / FORM / FUNCTION SHALL FOLLOW PS-E.008.
- (N2) 2. PLACE ITEMS# 5, 9 AND 10 IN SEPARATE BAG.
- (N3)  3. APPLY ADHESIVE LOCTITE 680 AND TIGHTEN TO 15-20 IN-LBS TORQUE

BILL OF MATERIAL (CURRENT LEVEL)

ITEM	PT/ASSY	DESCRIPTION	TYPE	QTY.
1	40553	ESCUTCHEON	PART	2
2	40530	POST	PART	1
3	6XXB	MOUNTING BRACKET	PART	2
4	92031	SCRW, M6 X 1 X 6 SKT HD CUP PT W/ SELF LOC SS	PART	2
5	1-206	HARDWARE PACK	ASSEMBLY	2
6	40579	FINIAL	PART	2
7	7-752	TISSUE ROLLER ASM	ASSEMBLY	1
8	40539	POST - RIGHT	PART	1
9	10615	HEX KEY, 3MM ALLOY STEEL	PART	1
10	91756	O-RING #2-134, EP, 50 DURO - GREY	PART	2
11	92125	SCRW, 10-24 X 3/8 SKT CAP HD SS	PART	2

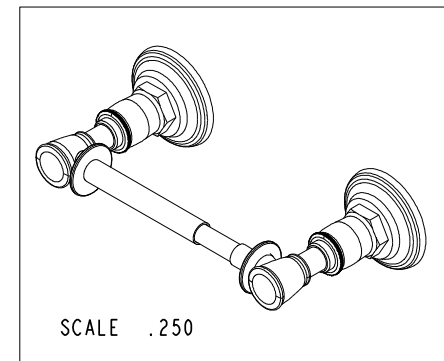
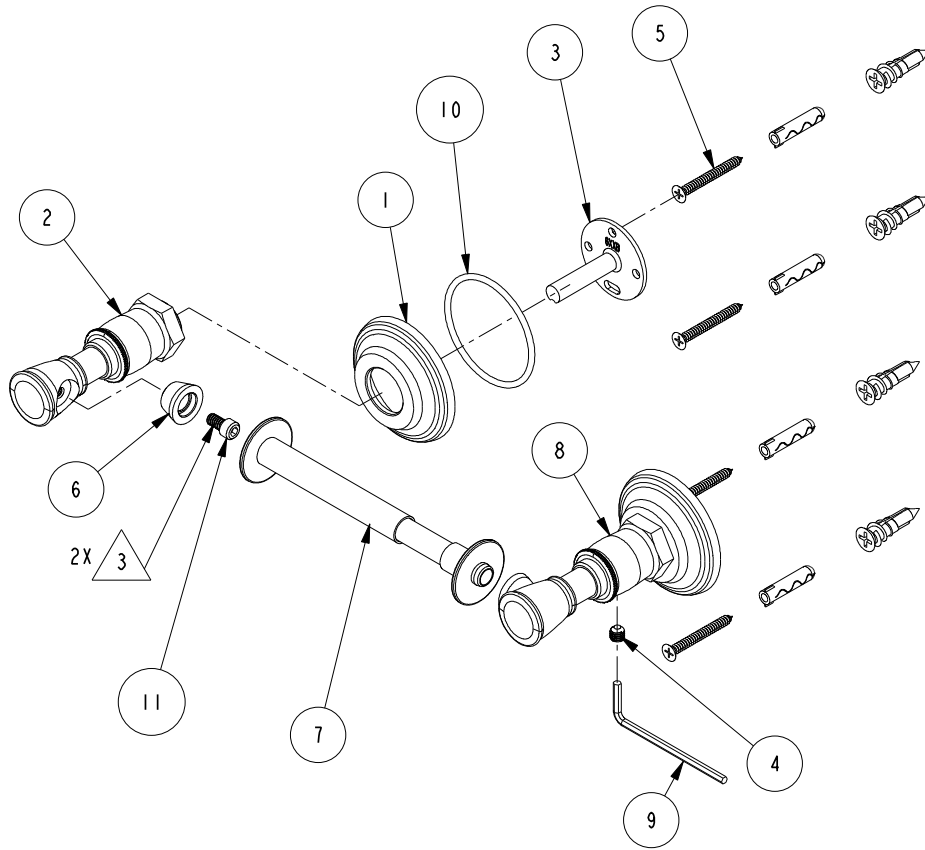

-	D	EN-4044	02/13/20	R. S.
-	C	EN-3722	02/08/19	C. G.
-	B	EN-3089	06/30/16	J. M.
-	A	EN-2717	04/16/14	-
-	-	EN-2086	09/01/13	-
ZONE	REV	DESCRIPTION	DATE	APPROVED

COPYRIGHT 2005 BRASSTECH, INC. THESE DRAWINGS AND THE DESIGNS DEPICTED HEREIN ARE THE PROPRIETARY PROPERTY OF BRASSTECH. ANY USE OR REPRODUCTION IS SUBJECT TO THE EXPRESS APPROVAL OF BRASSTECH. UNAUTHORIZED USE IS STRICTLY PROHIBITED. ALL RIGHTS RESERVED.

TESTING	-	-	-
ASSEMBLY	-	-	-
PLATING	-	-	-
POLISHING	-	NEXT ASSY	USED ON
MACHINING	-	APPLICATION	
TOOLING FIXTURE #	REMOVE ALL BURRS AND SHARP EDGES		

UNITS ARE: INCHES [MM]	
TOLERANCES ARE:	
FRACTIONS	DECIMALS
±1/16"	.X ±.1 [2.5]
	.XX ±.06 [1.5]
ANGLES ±1°	
(X.XXX) DENOTES CRITICAL DIMS.	
ALL THREADS ARE CRITICAL	
DRAWN	-
CHECKED	-
APPROVED	-

BRASSTECH		2001 CARNEGIE AVE. SANTA ANA, CA 92705 (949) 417-5207	
INCORPORATED			
TISSUE HOLDER			
DWG NO. 40-28			REV D
SCALE .313	REF. -	SHEET 1	OF 2

