

NOTES:

1. TO INSPECT ASSEMBLY, FOLLOW FIRST ARTICLE AND IN PROCESS INSPECTION SHEET.

BILL OF MATERIAL (CURRENT LEVEL)

ITEM	PT/ASSY	DESCRIPTION	TYPE	QTY.
1	403	1/2" COMP. X 3/8" SUPPLY VALVE	ASSEMBLY	1
2	435	SUPPLY TUBE FLAT HEAD 3/8 X 12"	ASSEMBLY	1
3	441	GRIP FLANGE (441)	PART	1

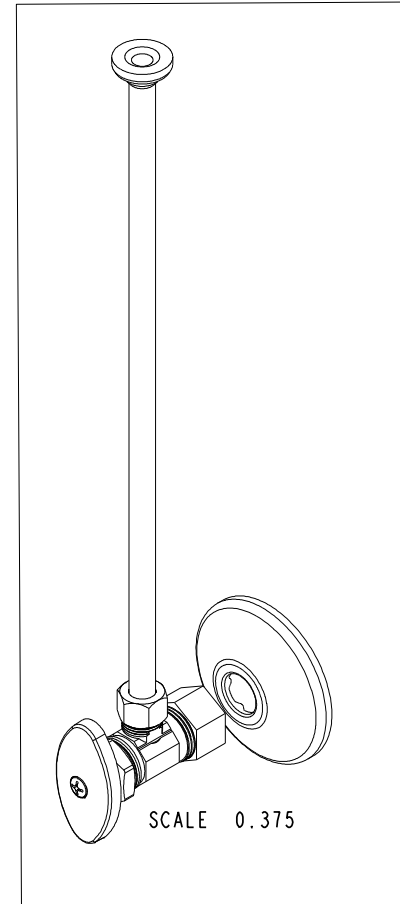
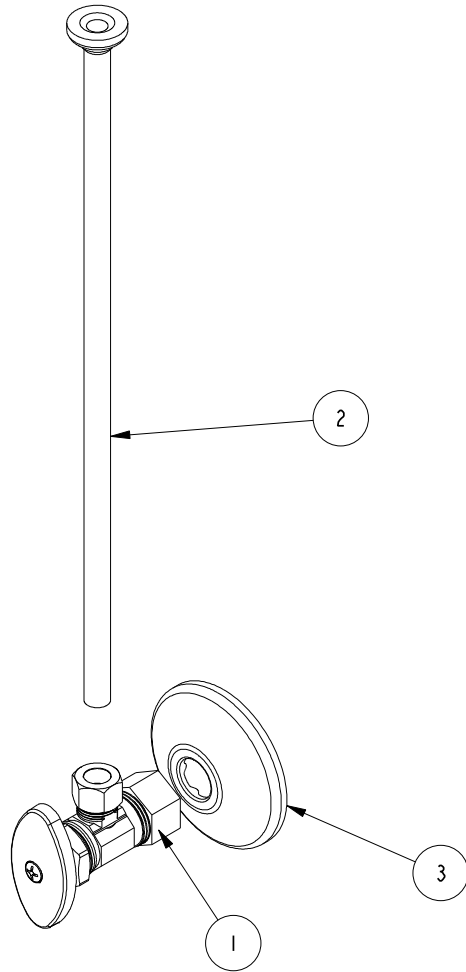

ZONE	REV	DESCRIPTION	DATE	APPROVED
-	A	EN-430011	10/21/21	R. S.
-	-	EN-2540	06/03/13	-

COPYRIGHT 2005 BRASSTECH, INC. THESE DRAWINGS AND THE DESIGNS DEPICTED HEREIN ARE THE PROPRIETARY PROPERTY OF BRASSTECH. ANY USE OR REPRODUCTION IS SUBJECT TO THE EXPRESS APPROVAL OF BRASSTECH. UNAUTHORIZED USE IS STRICTLY PROHIBITED. ALL RIGHTS RESERVED.

TESTING	-	-	-
ASSEMBLY	-	-	-
PLATING	-	-	-
POLISHING	-	NEXT ASSY	USED ON
MACHINING	-	APPLICATION	
TOOLING FIXTURE #	REMOVE ALL BURRS AND SHARP EDGES		

UNITS ARE: INCHES [MM]	
TOLERANCES ARE:	
FRACTIONS	DECIMALS
±1/16"	.X ±.1 [2.5]
	.XX ±.06 [1.5]
ANGLES ±1°	
(X.XXX) DENOTES CRITICAL DIMS.	
ALL THREADS ARE CRITICAL	
DRAWN	-
CHECKED	-
APPROVED	-

BRASSTECH
INCORPORATED

2001 CARNEGIE AVE.
SANTA ANA, CA 92705
(949) 417-5207

1/2" CMP. X 3/8" SUPPLY
KIT

DWG NO.	495	REV	A
SCALE	0.375	REF.	-
SHEET	1	OF	2

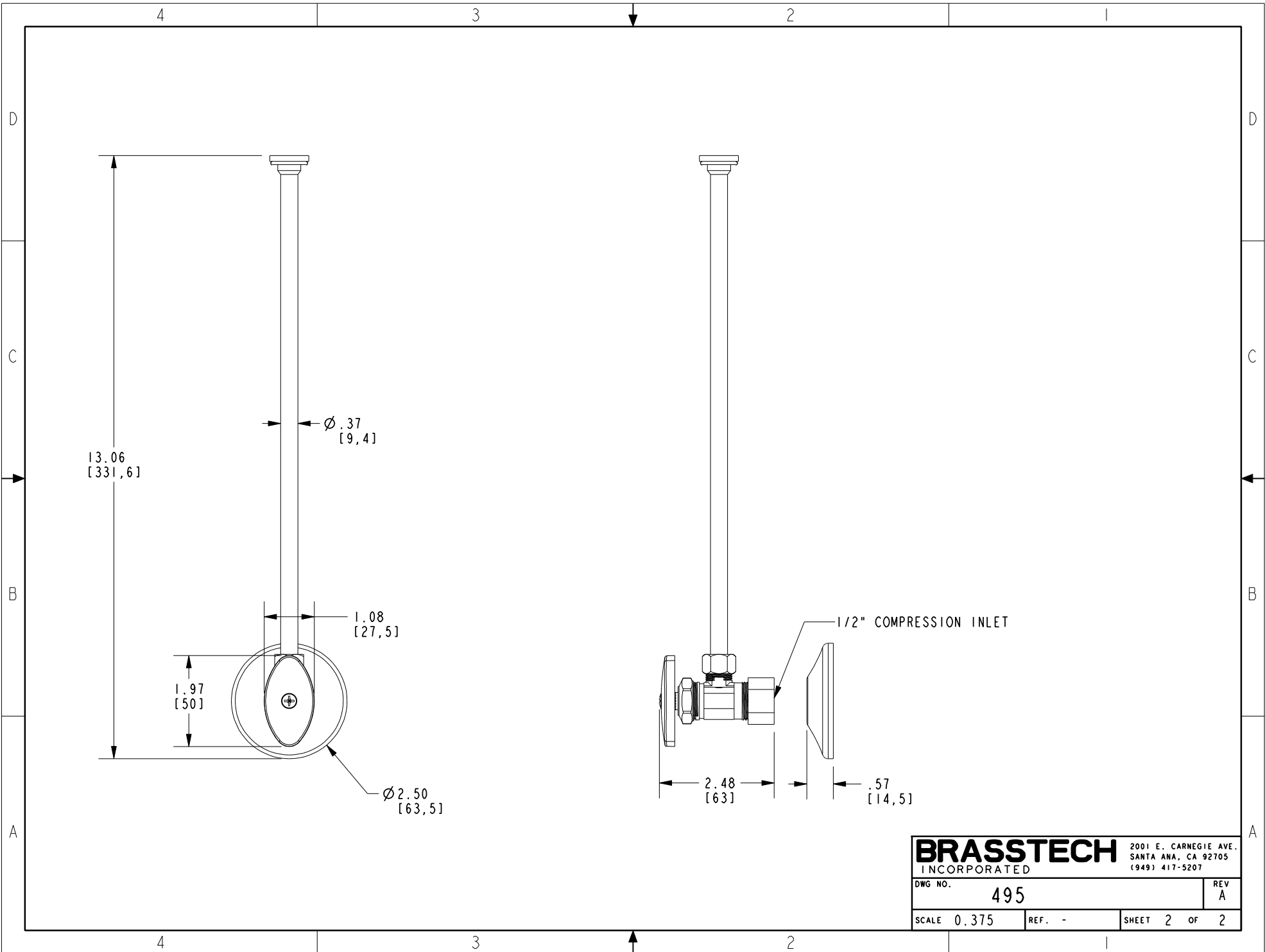

BRASSTECH		2001 E. CARNEGIE AVE. SANTA ANA, CA 92705 (949) 417-5207	
DWG NO.	495	REV	A
SCALE	0.375	REF.	-
SHEET		2	OF 2