

NOTES:

1. TO INSPECT ASSEMBLY, FOLLOW FIRST ARTICLE AND IN PROCESS INSPECTION SHEET.
2. SEAL NUT 10259 IN A PLASTIC BAG AND TAPE TO THE BACK OF THE TRIM PLATE.

**BILL OF MATERIAL (CURRENT LEVEL)**

ITEM	PT/ASSY	DESCRIPTION	TYPE	QTY.
1	2-438	COVERPLATE BP W/DIV ASM	ASSEMBLY	1
2	2-217	DIVERTER TRIM KIT	ASSEMBLY	1
3	3-649	CROSS HANDLE W/ESC.	ASSEMBLY	1
4	10259	HEX NUT 9/16 X 20 MADE	PART	1

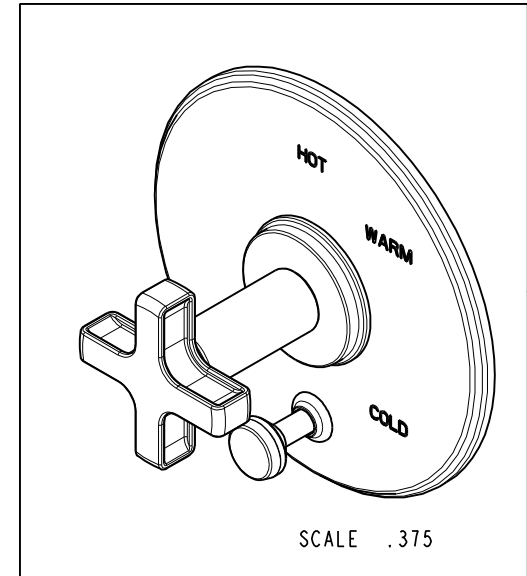
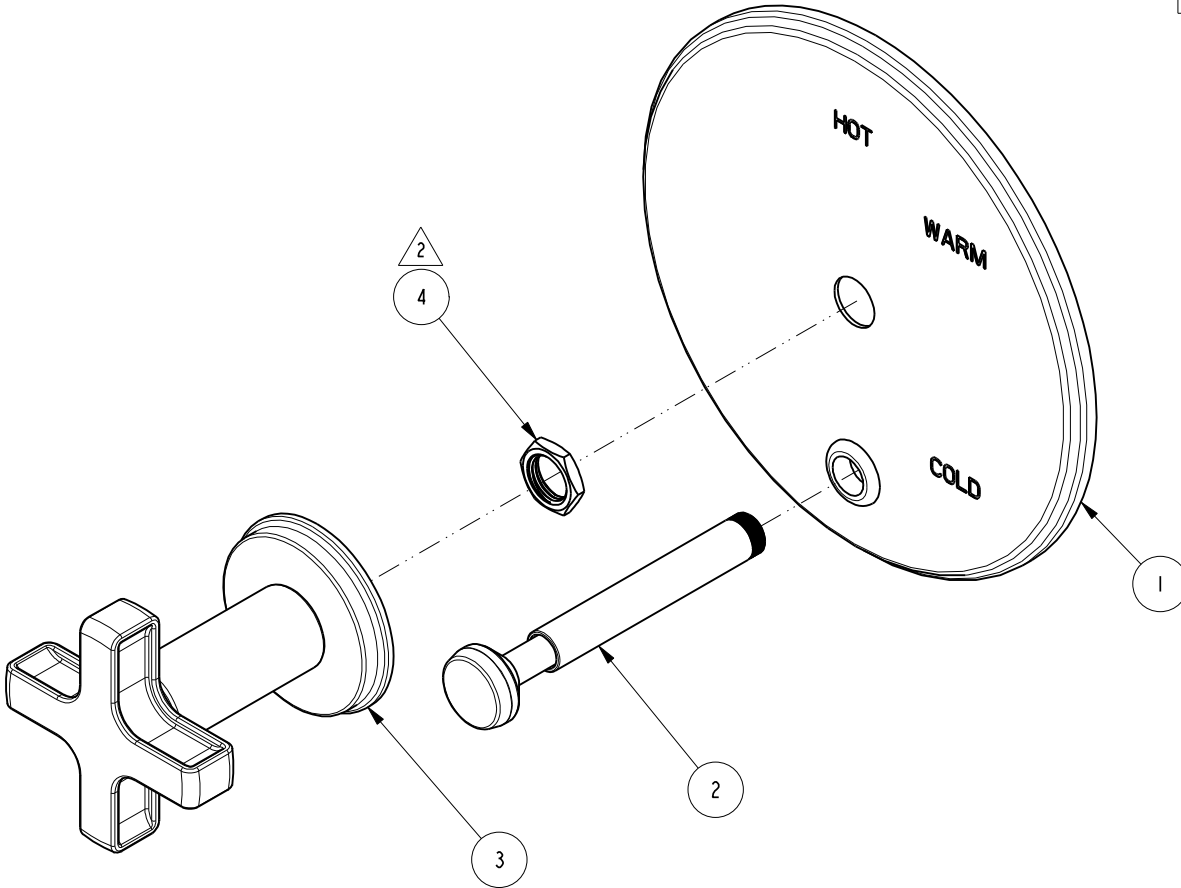

ZONE	REV	DESCRIPTION	DATE	APPROVED
-	B	EN-4441	04/18/22	N.S.
-	A	EN-3478-2	08/25/21	R.S.
-	-	EN-3478	03/13/19	J.M.

COPYRIGHT 2005 BRASSTECH, INC. THESE DRAWINGS AND THE DESIGNS DEPICTED HEREIN ARE THE PROPRIETARY PROPERTY OF BRASSTECH. ANY USE OR REPRODUCTION IS SUBJECT TO THE EXPRESS APPROVAL OF BRASSTECH. UNAUTHORIZED USE IS STRICTLY PROHIBITED. ALL RIGHTS RESERVED.

TESTING	-	-	-
ASSEMBLY	-	-	-
PLATING	-	-	-
POLISHING	-	NEXT ASSY	USED ON
MACHINING	-	APPLICATION	
TOOLING FIXTURE #	REMOVE ALL BURRS AND SHARP EDGES		

UNITS ARE: INCHES [MM]  
TOLERANCES ARE:  
FRACTIONS DECIMALS ANGLES  
±1/16" .X ±.1 [2.5] ±1°  
.XX ±.06 [1.5]

(X.XXX) DENOTES CRITICAL DIMS.  
ALL THREADS ARE CRITICAL

DRAWN	J.T.	04/18/22
CHECKED	N.S.	04/18/22
APPROVED	N.S.	04/18/22

**BRASSTECH** 2001 CARNEGIE AVE.  
INCORPORATED SANTA ANA, CA 92705  
(949) 417-5207

**BP TUB & SHOWER TRIM**

DWG NO.	5-3282BP	REV	B
SCALE	.500	REF.	-
SHEET	1	OF	2

