

NOTES:

- (N1) 1. FIT / FORM / FUNCTION SHALL FOLLOW PS-E.008.
- 2 APPLY ADHESIVE LOCTITE 680.
- 3 APPLY 3M SCOTCH-WELD DP-100NS OR EQUIVALENT.
- 4 REMOVE METAL BURRS.
- 5 SCORE SURFACE.

BILL OF MATERIAL (CURRENT LEVEL)

ITEM	PT/ASSY	DESCRIPTION	TYPE	QTY.
1	50787	ESCUTCHEON, AIR GAP	PART	1
2	50789	3/8" BARBED TUBE FITTING	PART	1
3	50772	1/4" BARBED TUBE FITTING	PART	1
4	50774	AIR GAP TUBE	PART	1
5	91381	TUBE, BLACK 1/4 OD X 4 FT	PART	1
6	91380	TUBE, BLACK 3/8 OD X 4 FT	PART	1
7	91753	O-RING, # 2-136, EP, 50 DURO - GREY	PART	1

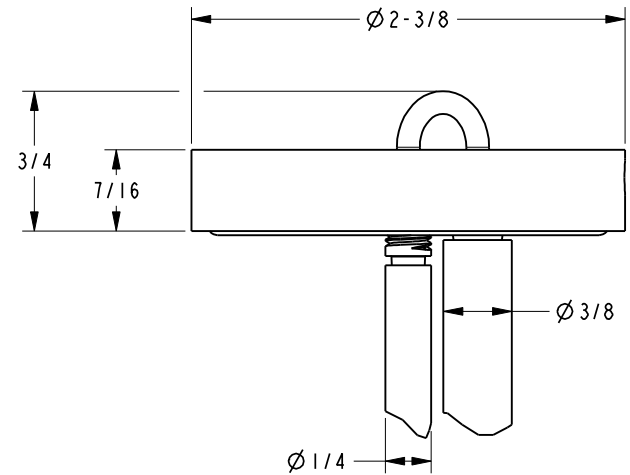
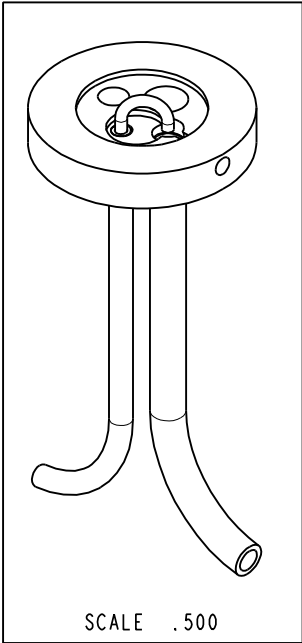

-	D	EN-3722	02/08/19	C.G.
-	C	EN-2186	06/27/12	-
-	B	EO-1079	08/20/08	-
-	A	EO-0463	01/10/05	-
ZONE	REV	DESCRIPTION	DATE	APPROVED

COPYRIGHT 2005 BRASSTECH, INC. THESE DRAWINGS AND THE DESIGNS DEPICTED HEREIN ARE THE PROPRIETARY PROPERTY OF BRASSTECH. ANY USE OR REPRODUCTION IS SUBJECT TO THE EXPRESS APPROVAL OF BRASSTECH. UNAUTHORIZED USE IS STRICTLY PROHIBITED. ALL RIGHTS RESERVED.

TESTING	-	-	-
ASSEMBLY	-	-	-
PLATING	-	-	-
POLISHING	-	NEXT ASSY	USED ON
MACHINING	-	APPLICATION	
TOOLING FIXTURE #	REMOVE ALL BURRS AND SHARP EDGES		

UNITS ARE: INCHES [MM]
TOLERANCES ARE:
FRACTIONS DECIMALS ANGLES
 $\pm 1/16"$.X $\pm .1$ [2,5] $\pm 1^\circ$
.XX $\pm .06$ [1,5]

(X.XXX) DENOTES CRITICAL DIMS. ALL THREADS ARE CRITICAL

DRAWN	MANJUNATH	02/08/19
CHECKED	C.G.	02/08/19
APPROVED	C.G.	02/08/19

BRASSTECH 2001 CARNEGIE AVE. SANTA ANA, CA 92705 (949) 417-5207
INCORPORATED

AIR GAP ASSY, CONTEMP

DWG NO. **6-027** REV **D**

SCALE .950 REF. - SHEET | OF |