

5100 SERIES - APPLICATIONS

REGULAR ARM MOUNT (PULL SIDE)

Opening:	Templating allows up to 120°
Hold Open:	Hold open points from 90° up to 120° with hold open arm
Frame Face:	1-1/4" (32 mm) minimum
Ceiling Clearance:	1-1/4" (32 mm) minimum
Top Rail:	<ul style="list-style-type: none"> • Less than 3-3/4" (95 mm) requires drop plate, 5109 • Drop plate requires 2" (51 mm) minimum
Top Rail Clearance:	4" (102 mm) from the top of door

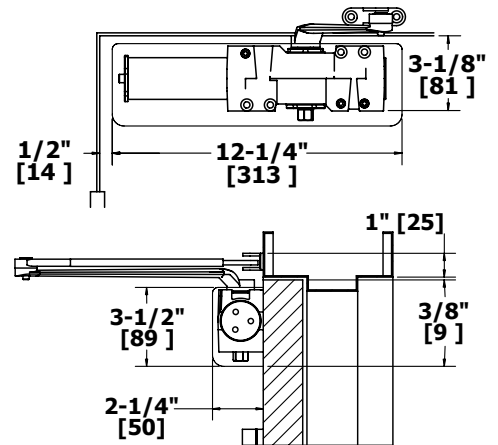

PARALLEL ARM MOUNT (PUSH SIDE)

Opening:	Templating allows up to 180°
Hold Open:	Hold open points from 90° up to 180° with hold open arm
Top Rail:	<ul style="list-style-type: none"> • Standard hollow metal 5/8" frame stop • Less than 5-1/2" (140 mm) from the stop requires drop plate, 5110 • Drop plate requires 2" (51 mm) minimum from the stop
Top Rail Clearance:	6-1/4" (159 mm) from the top of door

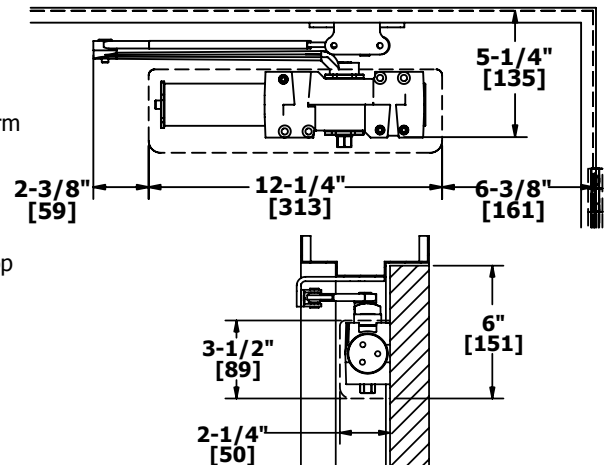

TOP JAMB MOUNT (PUSH SIDE)

Opening:	Templating allows up to 120°
Hold Open:	Hold open points 85° up to 120° with hold open arm
Frame Face:	Less than 3-1/2" (89 mm) requires drop plate, 5115
Ceiling Clearance:	Drop plate requires 4" (102 mm) minimum
Top Rail:	Requires 1-3/8" (35 mm) minimum
Top Rail Clearance:	1-1/2" (38 mm) from the top of the door

