

Architectural Door Accessories

ASSA ABLOY

Rockwood 320-RKW Latch Protector

The global leader in
door opening solutions

NOT TO SCALE

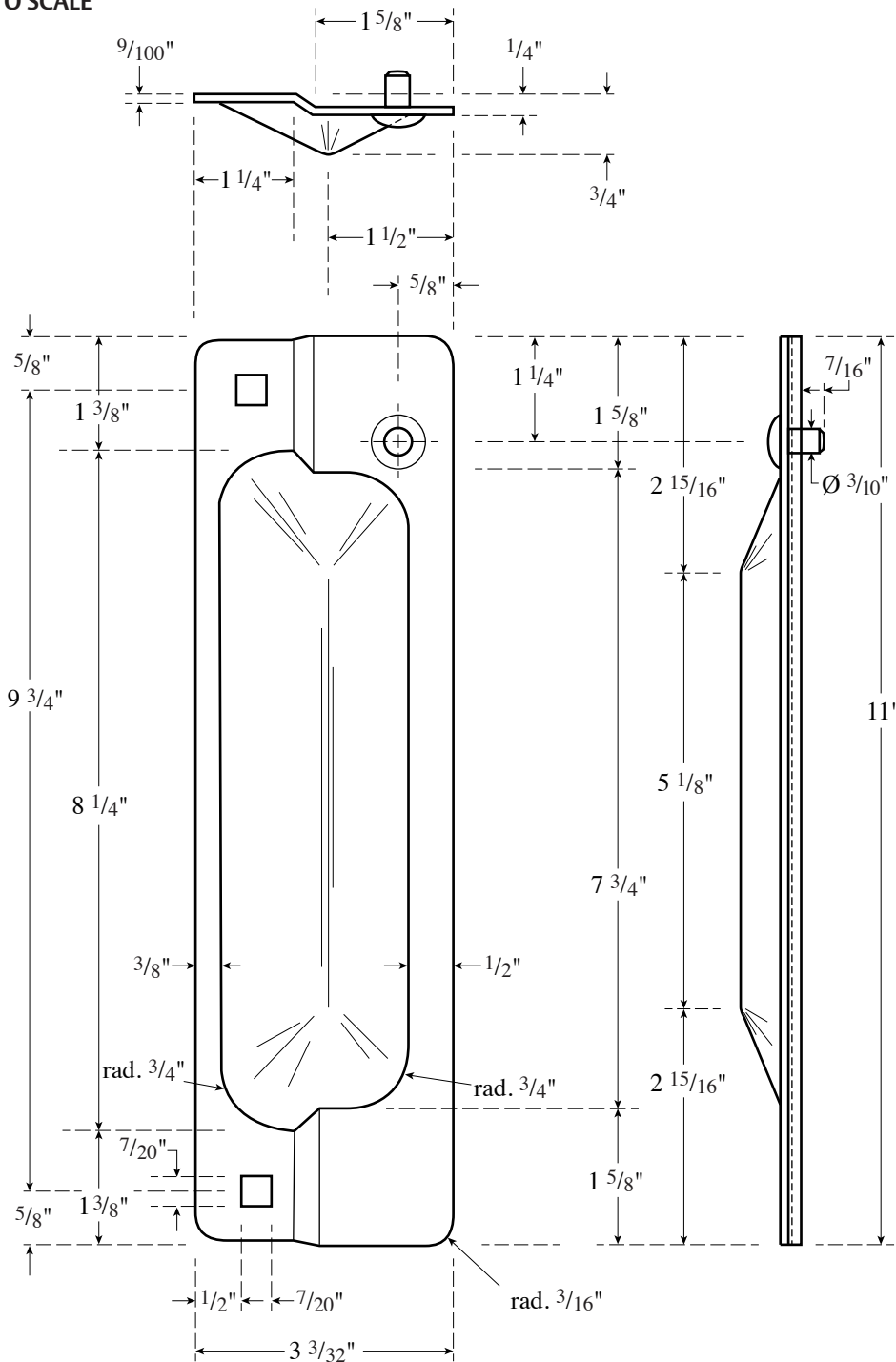

Template T-320-RKW

Effective date: January 1, 2017
Supersedes: All Previous

NOTE: ASSA ABLOY reserves the right to make product changes and is not responsible for obsolete template errors. To ensure your template is current, please visit our website at www.rockwoodmfg.com or call us at 800-458-2424

300 Main Street
Rockwood, Pennsylvania 15557
P: 800.458.2424 | F: 800.922.9212
www.rockwoodmfg.com | orders.rockwood@assaabloy.com

Copyright © 2017, Rockwood Manufacturing Company, an ASSA ABLOY Group company. All rights reserved.
Reproduction in whole or in part without the express written permission of Rockwood Manufacturing Company is prohibited.

T-320-RKW - 1/17